

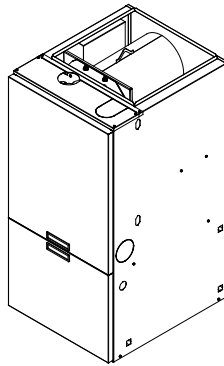

**OIL FIRED FURNACE
INSTALLATION AND OPERATION MANUAL
WITH USERS INFORMATION SECTION**

**MODEL:
OHCFA072DV4R**



⚠ WARNING: IF THE INFORMATION IN THESE INSTRUCTIONS IS NOT FOLLOWED EXACTLY, A FIRE OR EXPLOSION MAY RESULT CAUSING PROPERTY DAMAGE, PERSONAL INJURY, OR LOSS OF LIFE.

DO NOT STORE OR USE GASOLINE OR OTHER FLAMMABLE VAPORS AND LIQUIDS IN THE VICINITY OF THIS OR ANY OTHER APPLIANCE.

⚠ WARNING: IMPROPER INSTALLATION, ADJUSTMENT, ALTERATION, SERVICE, OR MAINTENANCE CAN CAUSE INJURY OR PROPERTY DAMAGE. REFER TO THIS MANUAL. FOR ASSISTANCE OR ADDITIONAL INFORMATION CONSULT A QUALIFIED INSTALLER, OR SERVICE AGENCY.

PLEASE READ THESE INSTRUCTIONS PRIOR TO INSTALLATION, INITIAL FIRING, AND BEFORE PERFORMING ANY SERVICE OR MAINTENANCE. THESE INSTRUCTIONS MUST BE LEFT WITH THE USER AND SHOULD BE RETAINED FOR FUTURE REFERENCE BY QUALIFIED SERVICE PERSONNEL.

THERMO PRODUCTS, LLC.
PO BOX 217
NORTH JUDSON, IN 46366
PHONE: (574) 896-2133



MO-490
ECN 5095-PC 131030



Made IN USA

CONTENTS

<u>SECTION</u>	<u>PAGE</u>
I. SAFETY SECTION.....	1
A. CODES AND CLEARANCES.....	3
II. GENERAL INSTRUCTIONS.....	5
A. VENTING.....	5
B. INSTALLATION OF VENTOR.....	7
C. CONDENSATE DRAIN LINE CONNECTION.....	10
D. DUCT WORK/AIR CONDITIONING.....	11
E. AIR FILTER MOUNTED EXTERNAL TO FURNACE.....	12
F. LIMIT POSITION AND LOCATION.....	14
G. BURNER INSTALLATION.....	14
H. BURNER SPECIFICATIONS AND APPLICATIONS.....	14
I. OILTANK AND PIPING.....	15
J. ELECTRICAL WIRIING.....	17
L. BLOWER MOTOR SPEED SELECTION.....	19
M. BLOWER CONTROLLER INFORMATION FOR ECM MOTOR.....	21
N. STARTUP PROCEDURES.....	25
III. USERS INFORMATION SECTION.....	31
A. OIL SUPPLY.....	31
B. INSPECTION AREAS.....	31
C. STARTING THE BURNER.....	31
D. FILTER CLEANING AND LOCATION.....	31
IV. INSTALLER'S INSTRUCTIONS TO USER.....	32
V. DEALER MAINTENANCE.....	33
A. GENERAL INSPECTION.....	33
B. HEAT EXCHANGER CLEANING INSTRUCTIONS.....	34
D. ELECTRICAL SYSTEM.....	37
E. SUPPLY/RETURN AIR BLOWER.....	37
F. SUPPLY/RETURN AIR FILTER.....	37
G. EXTENDED APPLIANCE SHUTDOWN.....	38
VI. HOMEOWNER/USER INFORMATION AND ROUTINE MAINTENANCE.....	40
VII. TROUBLESHOOTING.....	42
VIII. SEQUENCE OF OPERATIONS FLOW CHART.....	43
IX. TROUBLE SHOOTING FLOW CHART.....	45
APPENDIX – A	
REPLACEMENT PARTS LIST.....	49
APPENDIX – B	
WIRING DIAGRAMS.....	52

Model Number Digit	1	2	3	4	5	6	7	8	9	10	11	12
	Fuel	Configuration	Heat Exchanger Identifier	Flue	Feature	Capacity	Capacity	Capacity	Blower Type	Clg Airflow Cap.	Clg Airflow Cap.	Burner
Oil Furnace Model Nomenclature Example Model Numbers	O	H	C	F	A	0	7	2	D	V	4	R
O = Oil	O											
H = Highboy D = Downflow		H										
C = Heat Exchanger Identifier			C									
F = Front				F								
R = Rear												
A = Single Stage					A							
Heating Capacity MBTUH (000's) with factory installed nozzle						0	7	2				
D = Direct Drive									D			
Clg. Airflow: Example = 48MBTUH = 4 tons @ 400cfm/ton										4	8	
Clg. Airflow Variable Speed (ECM) V4 = 4tons										V	4	
R = Riello												R

I. SAFETY SECTION

This page and the following contains various warnings and cautions found throughout the Oil Furnace Manual. Please read and comply with the statements below.

△WARNING AND CAUTIONS:

△WARNING: This furnace is not to be used as a construction heater. **See Page 3**

△WARNING: The predetermined limit locations on all of the Thermo Pride oil fired furnaces have been tested and approved by Thermo Products, LLC. Any attempt to relocate these safety controls or replace these safety controls with a control that is not approved, or is incompatible, may result in personal injury, substantial property damage or death. **See Page 14**

△WARNING: **THE HEAT EXCHANGER MUST BE CLEANED BY A QUALIFIED SERVICE PERSON.** **See Page 34**

△CAUTION: **DO NOT ATTEMPT TO MAKE REPAIRS YOURSELF!** **See Page 31**

△WARNING: The area around the furnace should be kept free and clear of combustible liquids and material, especially papers and rags. **See Page 31**

△WARNING: **NEVER** burn garbage or refuse in your furnace. Never try to ignite oil by tossing burning papers or other material into your furnace. **See Page 31**

△WARNING: Thermo Products oil furnaces are designed to burn No. 1 or No. 2 distillate fuel oil. **NEVER USE GASOLINE OR A MIXTURE OF OIL AND GASOLINE.** **See Page 31**

△CAUTION: **DO NOT ATTEMPT TO START THE BURNER WHEN:**

1. Excess oil has accumulated,
2. The furnace is full of vapors
3. The combustion chamber is very hot.

IF ONE OR MORE OF THESE CONDITIONS EXIST, CONTACT A QUALIFIED SERVICE PERSON. **See Page 31**

△WARNING: **DO NOT START BURNER UNLESS BLOWER DOOR IS SECURED IN PLACE.**

△FOR YOUR SAFETY: **DO NOT STORE OR USE GASOLINE OR OTHER FLAMMABLE VAPORS AND LIQUIDS IN THE VICINITY OF THIS OR ANY OTHER APPLIANCE.**

⚠ WARNING

ANNUAL SERVICE REQUIRED

The following items should be inspected every year by a qualified heating servicer. (Shut off power before inspecting.) Correct any deficiencies at once. Failure to do so may result in injury, property damage or loss of life.

Heat Exchanger: Inspect for corrosion, pitting, warpage, cracks, deterioration, carbon build up and loose gaskets.

Burner: Check for correct operation, proper combustion, no fuel leakage, and replace burner oil filter.

Chimney/Vent Pipe: Inspect for restriction, loose joints, abnormal carbon build up and condensation.

Controls: Check for correct operation and proper settings, (if manually adjustable).

Periodic visual inspections should also be made by the owner during the heating season. Call a qualified heating servicer to report suspected deficiencies. (Do not attempt to make repairs yourself!)

Further owner and heating servicer responsibilities are detailed in the printed information provided with the furnace.

390399

⚠ WARNING

SPECIAL HOMEOWNERS INSTRUCTIONS

Improper installation, adjustment, alteration, service or maintenance can cause injury or property damage. Refer to the user's information section in the manual. For assistance or additional information consult a qualified installer, service agency or the gas/oil supplier.

390055

⚠ WARNING

REINSTALL ALL PARTS!

Should this unit be disassembled all components, panels, block offs, collars, gaskets, and fasteners must be reassembled as originally factory produced.

Failure to do so may result in property damage, injury, or loss of life.

390056

⚠ WARNING

HAZARDOUS VOLTAGE

Avoid contact with exposed live voltage terminals. Do not bypass or disconnect limit. Turn off power prior to service.

Failure to do so may result in property damage, injury, or loss of life.

390057

⚠ CAUTION

ROTATING FAN BLADE!

To avoid injury from hot or moving parts, shut off the furnace and allow to cool before removing this door.

When it becomes necessary to replace or wash filter, remove the dirty filter from the racks provided and wash or replace with identical new filters.

The blower motor located behind this door may or may not require lubrication. If lubrication instructions are not shown on the motor nameplate, the motor should not be lubricated. If the nameplate indicates that the motor requires lubrication, lubricate the motor as directed or use 30 drops of SAE 20 weight oil or equivalent twice a year. Do not use a light household grade oil.

390025

⚠ WARNING

PROFESSIONAL INSTALLATION AND SERVICE REQUIRED!

This unit must be installed and serviced by a qualified servicer. Failure to do so may result in property damage, injury, or loss of life.

390057



CONTROL NO. 2000990

MODEL NO. QHCFAD72DV4

SERIAL NO. 00000000



OIL FIRED FURNACE

CONFORMS TO UL STD 727 CERTIFIED TO CAN/CSA STD B140.4
FOR USE ONLY WITH RIELLO OIL BURNER MODEL BF3 C8511373

IDENTIFIER	INPUT BTU/HR	OUTPUT BTU/HR	R RIELLO NOZ. GPH/TYP	Q02 FOR MAX AFUE
-72+	75,000	72,000	0.50 60" W	11 1/2-12%

PUMP PRESSURE 145 PSI

+ FACTORY EQUIPPED NOZZLE. USE NO. 2 (DISTILLATE) FUEL OIL.

FOR MAXIMUM EFFICIENCY (AFUE) SET THE BURNER COMBUSTION AS INDICATED IN THE CHART ABOVE. DO NOT EXCEED A TRACE SMOKE SPOT AND A 65° F TEMPERATURE RISE.

ELECTRICAL SPECIFICATIONS 120 VOLTS 60 HZ 1 PHASE

TOTAL CURRENT (AMPS) 11.5

MINIMUM CIRCUIT AMPACITY 13.3

MAXIMUM FUSE SIZE (AMPS) 15

10865 (1/12) 11" x 14" 90°
1086 (1/12) 10" x 14" 90°

THERMO PRODUCTS, LLC.

P.O. BOX 217 NORTH JUDSON, IN 46366

DIRECT DRIVE BLOWER

EXTERNAL STATIC PRESSURE (INCHES W.C.) 0.20 TO 0.50
MAXIMUM DESIGNED OUTLET AIR TEMPERATURE 180°F OR LESS

FOR INSTALLATION IN A CLOSET OR ALCOVE ON COMBUSTIBLE FLOORING WITH CLEARANCES TO UNPROTECTED COMBUSTIBLE MATERIAL NOT LESS THAN:

ANY SIDE OF SUPPLY	PLENUM	TOP	SIDES	REAR	FRONT	FLUE PIPE
(INCHES)	1	1	0	0	6*	0

* 24 INCHES FOR SERVICE PURPOSES

CLOSET INSTALLATION REQUIRES TWO SEPARATE VENTILATION OPENINGS LOCATED 6 INCHES FROM THE TOP AND BOTTOM OF THE CLOSET DOORS OR PANELS MEASURING NOT LESS THAN 17 INCHES WIDE BY 8 1/2 INCHES HIGH.

10865 (1/12) 11" x 14" 90°
1086 (1/12) 10" x 14" 90°

The entire text of these instructions must be read and understood, before installing the appliance. It is the installer's responsibility to do the following:

1. Inform and demonstrate to the user, the correct operation and maintenance of the appliance, as explained in the **Homeowner/User Information and Routine Maintenance** section of this manual.
2. Inform the user of the hazards of flammable liquids and vapors and to remove such liquids and vapors from the vicinity of the appliance.
3. Inform the user of all pertinent warnings and precautions concerning this appliance.

⚠WARNING: This unit is not to be used for temporary heating of buildings, or structures, under construction. Construction dust may enter the appliance or the duct system and cause a fire hazard. Certain chemicals used during construction when burned, form corrosive condensate that can substantially reduce the life of the heating system heat exchanger.

This appliance is shipped completely assembled and internally wired. All electrical wiring has been factory installed and inspected. At the time of installation, the unit will require connection to electric power, fuel oil supply, and supply and return air ductwork. In the event of a shortage of parts or damage, contact Thermo Pride office.

This unit uses a fan-assisted combustion system, consisting of a pressure atomizing, oil burner and combustion air blower, used to push the products of combustion through the heat exchanger system. After installation, the furnace and duct system must be adjusted to obtain a temperature rise of 50°F to 80°F through the unit. (Refer to the rating label located on side panel inside the burner compartment). The installation must conform with local codes or, in the absence of local codes, with the Standard for the Installation of Oil-Burning Equipment, NFPA 31-1997, or the latest edition, and to these instructions. The installation must also comply with CSA B139 for recommended installation practices where applicable.

A. CODES AND CLEARANCES:

The following items must be considered when choosing the size and location of the unit.

1. **All local codes and/or regulations take precedence over the instructions in this manual and should be followed accordingly.** In the absence of local codes, installation must conform to these instructions and the guidelines of the National Fire Protection Association (NFPA). Two applicable NFPA installation codes are the National Electrical Code, ANSI/NFPA 70-1999, and Standard for the Installation of Oil-Burning Equipment, NFPA 31-1997. The latest editions of these codes should be consulted.
2. The selection of a heating unit should be based on a rate of heat loss calculation for the residence according to the manuals provided by the Air Conditioning Contractors of America (ACCA) or the American Society of Heating, Refrigeration, and Air Conditioning Engineers (ASHRAE). The heating capacity of the unit proposed for installation should meet or slightly exceed the rate of heat loss for the residence. Over sizing should not exceed 25% of the heat loss calculation.
3. When installed, this unit should be level. If possible, it should be installed in a central location, with respect to outlet registers of the supply air ductwork.
4. A furnace installed in a residential garage must be installed so the burner and ignition source are located higher than 18 inches above the floor. The furnace must also be located or protected to avoid physical damage by vehicles.
5. Definitions of "combustible" and "non-combustible" materials as presented in the latest edition of the National Fuel Gas Code, ANSI Z223.1/NFPA 70, are as follows:

a. Combustible material:

“...materials made of or surfaced with wood, compressed paper, plant fibers, or other materials that are capable of being ignited and burned. Such materials shall be considered combustible even though flame proofed, fire-retardant treated, or plastered.”

b. Non-combustible material:

“...material that is not capable of being ignited and burned; such as material consisting entirely of, or a combination of, steel, iron, brick, concrete, slate, asbestos, glass, and plaster.”

⚠WARNING: Carefully read and thoroughly understand the following guidelines and warnings before continuing with the installation of this appliance. Failure to follow these guidelines can cause improper and unsafe operation of this appliance. Unsafe operation can result in substantial property damage, severe personal injury, or death.

1. This appliance shall be used with only the type of fuel oil for which it is approved. Refer to the appliance-rating label for the required type of fuel.
2. This appliance is an oil-fired furnace designed for installation on non-combustible materials.
3. Ensure that adequate combustion and ventilation air is available to the unit.
4. The airflow resistance of the duct system attached to this appliance must fall within the allowable external static pressure range for this unit. Refer to the **Airflow Requirements and Sizing of Ductwork** section of this manual.
5. Make sure supply and return air ducts are completely sealed to the appliance casing. Refer to the **Airflow Requirements and Sizing of Ductwork** section of this manual.

Table 1: MINIMUM CLEARANCES TO COMBUSTIBLE MATERIALS

TYPE OF UNIT	MODEL NO.	FROM SIDES OF FURNACE	FRONT	TOP & SIDES OF PLENUM	FROM THE FLUE/VENT	REAR
Highboy	OHCFA072DV4R	0"	Note ¹	1"	0"	0"

Note: ¹ OHC front clearance 6" for Closet, 24" for Alcove.

The minimum clearances listed in the preceding table are for fire protection. Clearance for servicing the front of the furnace should be at least 24 inches.

NOTE: The OHC furnace is approved for closet installation.

II. GENERAL INSTRUCTIONS

A. VENTING:

The OHC furnace venting system must be installed by a qualified service person in accordance with local installation codes and these instructions. In the absence of applicable local codes, conform to the National Fuel Gas Code, NFPA 54/ANSI Z223.1 or latest edition.

Installation shall, at least, conform to the following requirements.

1. The exhaust vent/combustion air intake termination specified by Thermo Products, in this manual, shall be used.
2. **All plastic pipe and pipefittings sourced to complete the exhaust vent and air intake systems shall be constructed of rigid PVC (polyvinyl chloride) plastic. All components shall have a wall thickness equivalent to Schedule 40 series materials.**

In addition, all sourced PVC components shall be listed by a nationally recognized testing agency (e.g. NSF, UL, etc.) as conforming to one (1) or more of the following design standard.

<u>PVC Pipe Designation</u>	<u>Design Standard</u>
DWV (Drain-Waste-Vent)	ASTM-D2665
Schedule 40	ASTM-D1785

3. The exhaust vent pipe and combustion air pipe shall be at least as large as the exhaust vent/ air intake pipe specified by Thermo Products. **Size reduction is never permissible.** The required exhaust vent/ air intake pipe size is 3".
4. The furnace model series OHC shall **not** be common vented with any other appliance, including those burning solid fuels.
5. All horizontal runs of exhaust vent pipe shall slope upward at least ¼ inch per foot from the outlet of the furnace to the venter connection. This slope will permit proper drainage of the condensate.
6. The exhaust vent pipe shall be supported at every joint (no more than 4-feet between supports) to prevent pipe blockage due to condensate trapped at a local low point, or sag, in the vent system.
7. The **maximum permissible length of piping** (consisting of a combination of straight pipe and a corresponding number of elbows) permitted is: (Each elbow equals 5 ' of straight pipe).
 - **55 equivalent feet**, for the **exhaust vent system**,(eg. 25' of straight pipe & 6 elbows)
 - **65 equivalent feet**, for the **combustion air intake system**, (eg. 35' of straight pipe & 5 elbows).
8. When counting pipe elbows, **all** elbows used in the exhaust vent or combustion air intake systems must be considered. This includes all elbows, or equivalent pipefittings, used inside the furnace jacket. **Allow 5' for each elbow.**
Note: Two (2), 45⁰ elbows can be substituted for one (1), 90⁰ elbow.

Care should be taken to design the shortest possible intake and exhaust systems. Each system should contain as few elbows as possible to insure the satisfactory operation of the furnace. However, **system length should never be less than 8 ft of pipe with two (2), 90 deg. elbows.** For best overall operation of the combustion system, we recommend the actual equivalent lengths for both the constructed intake and the exhaust systems have approximately the same value.

9. The furnace comes with two 3" street elbows. The first street el shall be affixed to the secondary outlet collar either for left or right hand venting direction. First slide the black radiator hose (parts bag) over the metal exhaust collar. Next, slide 2 band clamps over the radiator hose. Then insert the PVC street el into the collar making sure to push the elbow all the way in until it stops. Finally the band clamps can be positioned and tightened. If you are venting left or right, simply continue venting with 3" PVC making sure to seal all connections. If you desire to vent thru the top right of the cabinet, utilize the second street el and line it up accordingly. (See Figure 1)

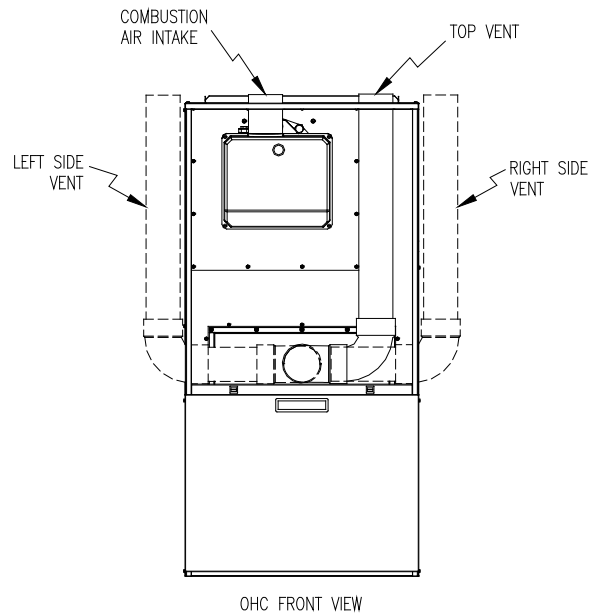

Fig-1

10. Use a saw designed to cut thermoplastic pipe. All cuts should be made at right angles to the pipe wall. Smooth jagged edges and remove all burrs and strings. Clean all pipe surfaces at connections using a fine abrasive material or approved PVC cleaner (primer). Secure all pipe joints using suitable permanent PVC pipe solvent cement. Joints are **NOT** to be made by simply gluing raw edges of butted together vent pipe.

Notice: Piping joints inside the furnace vestibule should be sealed with silicone caulk, rather than pipe cement, to allow for disassemble and removal of piping, if necessary, during maintenance.

Notice: Use silicone caulk to seal the pipe to the metal air intake collar on the burner, and then secure with a sheet metal screw.

11. Vent connections shall be visually checked for leakage.
12. Vent pipe passing through an unheated space shall be insulated with 1-inch thick, foil-faced

fiberglass insulation, or equivalent, to prevent freezing of condensate within the pipe.

13. No clearance is required from the outer surface of the thermoplastic piping to combustible materials for fire hazard prevention. No clearance is required from the outer surface of the ventor assembly either.
14. When attaching the 3" PVC to the burner combustion air inlet collar, first apply a bead of RTV sealant to the burner inlet collar only to ensure an airtight seal. Next, affix the PVC to the collar with a $\frac{3}{4}$ x #8 sheet metal screw. This can be driven right into the collar and may protrude into the airway.

B. INSTALLATION OF VENTOR:

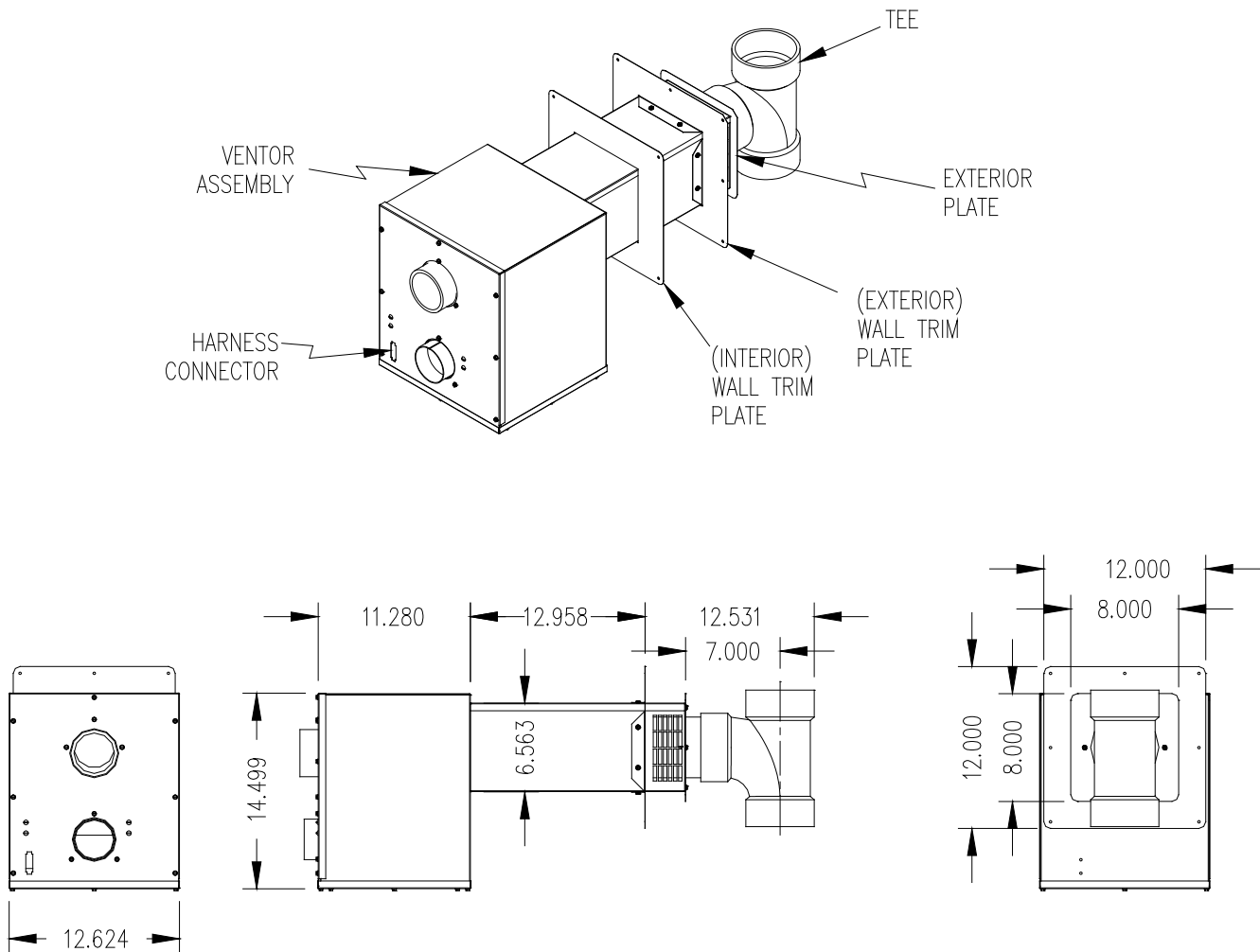

Fig-2

NOTICE: Ventor assembly must be installed so that it is level. If unit is not level, condensate will leak in to ventor box thru inducer and potentially freeze.

1. The OHC must be installed with the side-wall ventor/ blower assembly. **Do Not** attempt to operate the OHC without the ventor assembly as this could result in damage to the appliance or home.
2. No clearance is required from the outer surface of the ventor assembly to combustible materials for fire hazard prevention.
3. The ventor is designed to fit in between the joist space of 16 O.C.
4. Maximum wall thickness for the ventor assembly is 12".

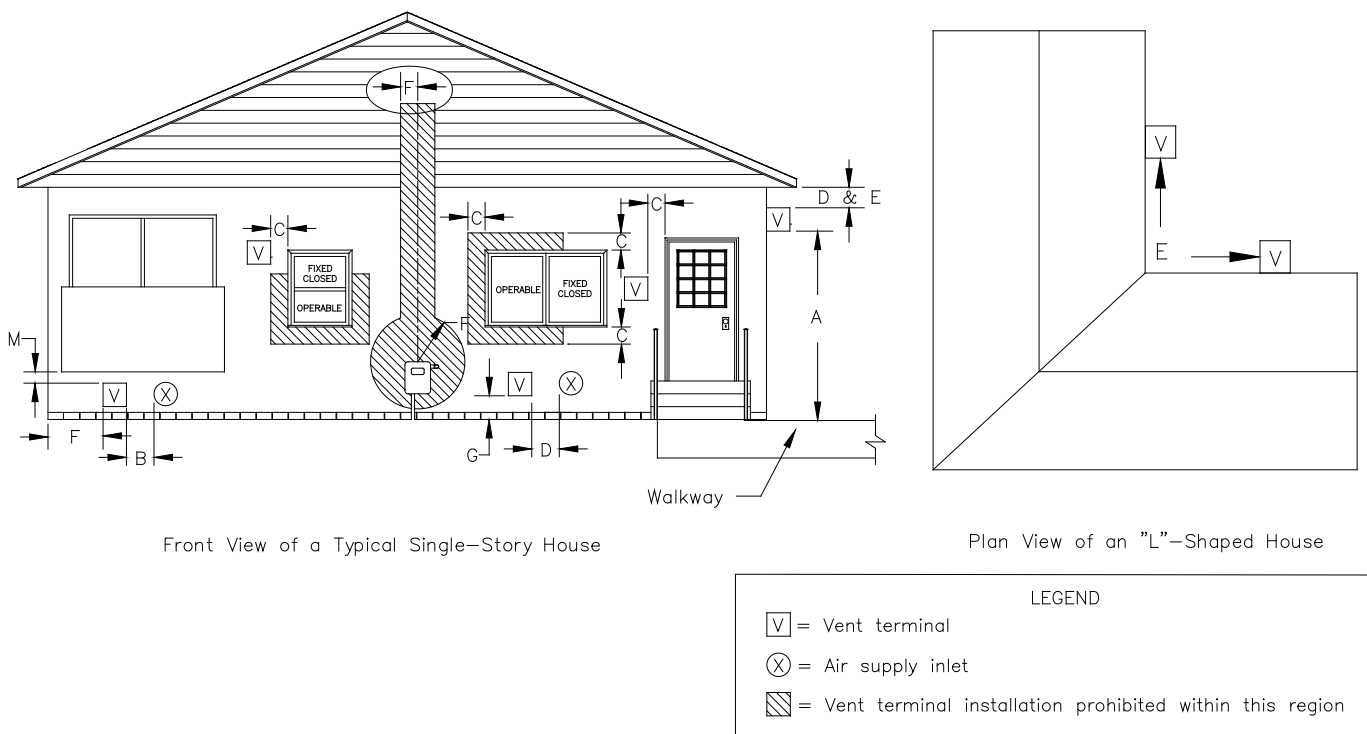

Fig-3

5. Remove vent system components from box and inspect for damage. If the carton has been crushed or mutilated, check components very carefully for damage. **DO NOT** install if any damage is apparent.
6. Remove the vent tee from the vent pipe. Set the tee aside for now. Remove the exterior plate also.
7. See Fig. 3 for vent terminal location. As a general rule, location of the termination of the venting system should be installed in accordance with the National Fuel Gas Code, ANSI Z223.1, manufacturer's recommendations, and/or local codes that are applicable. Refer to the following requirements or See Fig. 3 for typical locations.

- A. The exit termination of the draft system shall not be less than 7' above grade when located adjacent to public walkways.
 - B. The venting system shall terminate at least 3' above any forced air inlet located within 10' horizontally.
 - C. The venting system shall terminate at least 4' horizontally from, or 1' above any door, window or gravity air inlet into the building.
 - D. The vent termination shall be located at least 12" from any opening through which vented gases could enter the building.
 - E. The vent termination point shall not be installed closer than 3' from an inside corner of an L-shaped structure.
 - F. The vent termination should not be mounted directly above, or within 4' horizontally from an oil tank vent or gas meter.
 - G. The bottom of the vent tee outlet shall be located at least 12" above finished grade.
8. After determining the location of the venting system termination point (See Diagram A), cut a hole in the wall 7" x 7".
 9. Mount the ventor assembly through the wall opening. Fasten the exterior trim plate to the ventor body with the provided screws and a bead of silicone sealant. Then secure the trim plate to the outside wall with silicone sealant and the appropriate fasteners. Install the 4" PVC Tee as shown in Fig. 2 using silicone sealant and a sheet metal screw to secure.
 10. Use plumbers strapping or equivalent means to support the ventor main body. When supporting the main body, care must be taken to ensure the unit is level.
 11. The 25" cable provided with the ventor connects power from the furnace to the ventor blower and pressure switches. The molex connection plugs in to the ventor assembly connection, (See Fig. 2). The other end is connected to the furnace plug. The cable should be securely supported.
 12. If local codes require that the cable be run through a conduit, remove the molex end with a molex pin removal tool or equivalent. Care should be taken to not damage the pins. Run the cable through the conduit and then replace the molex plug.
 13. Connect the 3" PVC exhaust pipe to the ventor exhaust connection with a 3" coupling. Use silicone sealant to seal and a sheet metal screw to secure.
 14. Connect the 3" PVC combustion air pipe to the ventor opening with 3" pipe. Use silicone sealant and a sheet metal screw to secure.

C. Condensate Drain Line Connections:

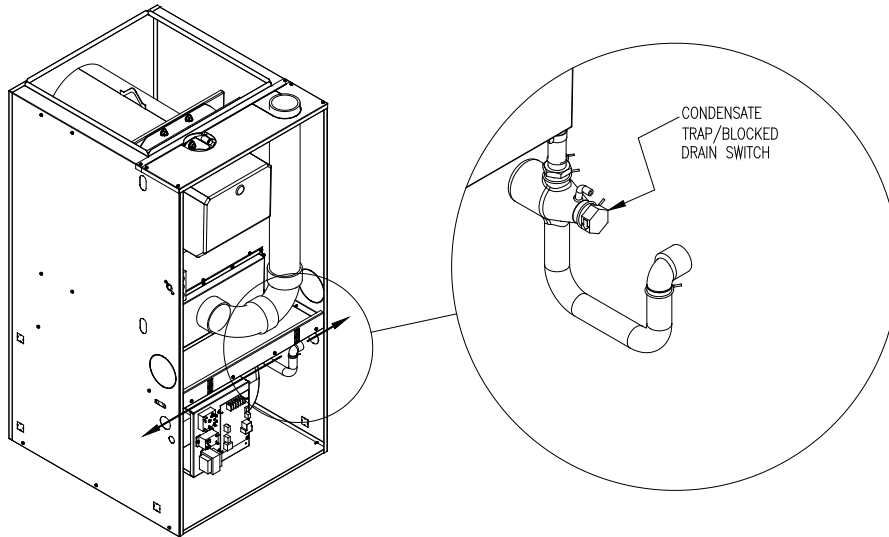

Fig-4

1. The trap/blocked drain switch assembly comes pre-mounted to the underside of blower pan just below the secondary drain port on the right side of the furnace. Prior to installing the drain, the PVC elbow must be sealed to the plastic trap with silicone and then the spring clamp applied. This positioning of the elbow can be turned to right for exiting the right side casing or rotated 180° and exit the left side of the furnace. In either case, secure the desired length of ½" PVC to exit the drain line hole in the appropriate side casing. The knock-out must be removed first and then the grommet included in the parts bag must be used to seal the PVC to the side casing.

Notice: It must be noted that the condensate drain line cannot exit the furnace on the same side as the filter rack due to interference.

2. Plan, source, and install a condensate drain line using ½ diameter PVC (polyvinyl chloride) thermoplastic pipe and pipefittings. Route the line in the shortest possible manner to reach a nearby drain. Secure all joints using PVC cement. For gravity drainage, the condensate drain line must maintain a minimum ¼ inch per foot downward slope toward drain. The drain line must be watertight, supported and secured such that it cannot be easily moved.

Notice: If an air conditioning condensate drain line is combined with the furnace condensate drain line, the air conditioning evaporator coil must have a separate trap installed ahead of the connection joint.

3. The OHC furnace is equipped with a blocked drain switch to prevent the furnace from continued operation in the event of a blocked or slow draining drain. This switch is wired in series with the T & T circuit (see wire diagram page 54 for details) and will open if the water level gets too high. This is non-adjustable and cannot be by-passed.

4. A condensate pump may be required when:

- a suitable drain is not present,
- the drain is above the trap outlet level on the furnace, or
- the drain line cannot be sloped downward its full length to the drain.

If gravity drainage of the condensate from the furnace to a drain is impractical for any of these reasons, a condensate pump (part #350225) is available from Thermo Products. Follow the pump manufacturer's instructions for proper installation.

5. **CAUTION: Continual exposure to condensate may injure plants and damage certain building materials, including metal, wood, stone, and concrete.**

Flue gas condensate is slightly acidic with a pH of about 3.5. (A pH level of 7.0 is considered neutral. Carbonated cola drinks with a pH of 3.1 are actually slightly more acidic than condensate.) If local codes require an acid neutralizing kit, a kit is available from Thermo Products under part no. 320095.

Follow the instructions enclosed with the neutralizing kit for proper installation.

6. The condensate piping in the furnace and the drain system should be flushed out at the start of every heating season. This will ensure trouble free operation and will keep the acidity level well above a pH of 3.4, i. e. more towards neutral.

To flush the condensate drain system, follow these steps.

- a. Turn off electrical power to the furnace at the disconnecting switch and adjust the room thermostat to "OFF", or to the lowest temperature setting.
- b. Flush the drain system by removing the drain hose from the secondary heat exchanger coil drain nipple and running tap water into the open end of the tubing. Run at least a quart of water through the drain system or more, until the water leaving the drain system is clear and colorless in color and free of any particulate matter.
- c. Replace the drain tubing by pushing it firmly onto the nipple. Make sure the spring-type hose clamp is returned to the original position to prevent leaks.
- d. If any of the electrical controls are inadvertently wetted during the flushing process, dry them with a soft cloth and wait 24 hours before operating the furnace.
- e. Adjust the room thermostat to the "HEAT" position, or to the desired temperature, and restore electrical power to the furnace.

D. DUCT WORK/AIR CONDITIONING:

Design and installation of the duct system should follow the current guidelines of the Air Conditioning Contractors of America (ACCA) or the American Society of Heating, Refrigeration and Air Conditioning Engineers, Inc. (ASHRAE). Refer to the Residential Duct Systems, Manual D, from the ACCA, and the ASHRAE Handbook Fundamentals volume, from the ASHRAE, for recommended practices in the duct system design and installation. To obtain copies of these publications for a fee, contact the ACCA and the ASHRAE, at the addresses given in Appendix A of this manual.

All furnaces are tested over a range of external static pressure that simulates the airflow resistance of the ductwork, fittings, and diffusers connected to the furnace for a typical (average) duct system. The furnace

blower and blower motor have been selected to work successfully against the following range of duct system resistance.

Recommended range of duct system resistance for all models: 0.2 to 0.5 in. W. G. external static pressure.

Due to the need to maintain an adequate supply of combustion and ventilation air, the furnace shall not be installed in small room without return air duct system. A duct the full size of the furnace return air opening shall extend to a location outside the furnace room.

If the furnace is used in connection with summer air conditioning (cooling), the furnace should be installed in parallel with, or on the upstream side of, the evaporator coil to avoid water vapor condensation in the furnace heat exchanger. If the cooling unit is installed in a parallel flow arrangement, dampers (or other means used to control airflow) should be provided to prevent chilled air from entering the furnace. If such damper is manually operated, it must be equipped with a means to prevent operation if either unit, unless the damper is placed in either the full heat or full cool position.

NOTICE: Return air grilles and supply registers in the air distribution system should never be obstructed.

The duct system shall be designed for the maximum CFM requirements of the installation whether it is for heating or cooling. Two common rules are as follows: 1.) 400 CFM/ton cooling 2.) 14 CFM/1000 BTU'S heating for 55°-85° Temp. Rise. The most common location for the A-shaped coil (A style) is shown in Fig. 5.

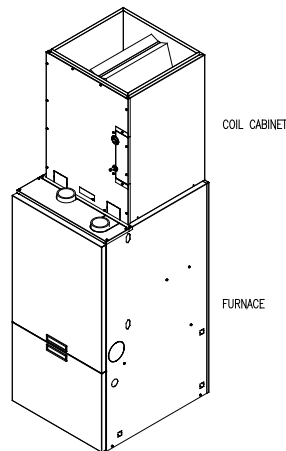

Fig-5: Furnace with coil cabinet

NOTICE: The minimum coil pan clearance for a sectional or drum type heat exchanger is three inches unless specified otherwise by the individual coil manufacturer.

E. Air Filter Mounted External to Furnace:

On **highboy** furnaces, it is necessary to cut the return air opening in the side, rear casing or base, depending upon the needs of the specific installation.

The filter rack provided with the furnace, refer to Fig. 6, can serve as a template to scribe a mark for the return air opening on the casing. Place the filter rack on a side casing approximately one inch up from the bottom of the furnace and centered from side to side. Place the securing flange against the casing when locating the return air opening. For your convenience, (3) locator knockouts have been placed at the proper locations on both the left and right side casings. Cut the opening to the O. D. of the knock-outs.

Now the filter rack can be anchored to the furnace with screws or pop-rivets through the securing flange of the filter rack.

Connect the return air plenum to the filter rack and slide the filter into place. Dimensions for adapting the return air plenum to the filter rack are provided (See Fig. 6).

Note: Filter rack and condensate drain must be on separate sides of the furnace.

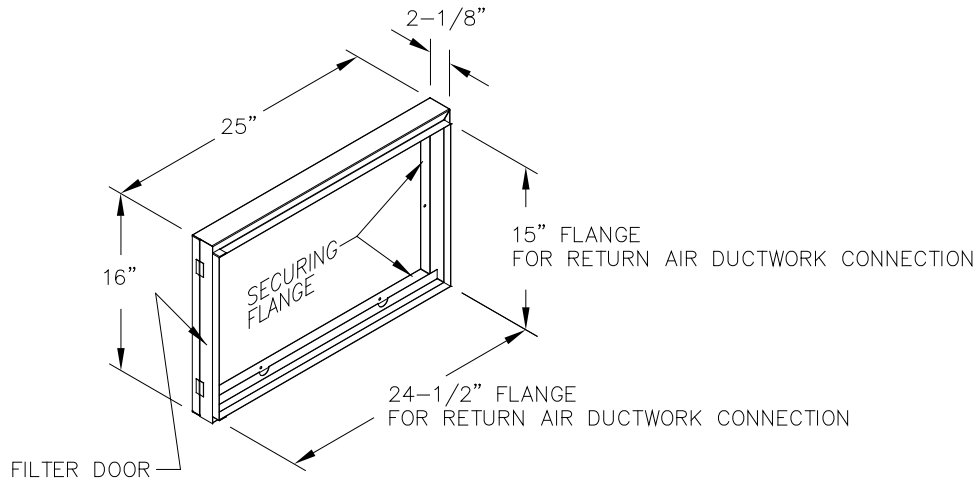

Fig-6 A typical filter rack and dimensions for the OHC furnace.

⚠CAUTION: Failure to comply with minimum filter installation requirements may affect the performance and/or void the warranty on this unit.

If a method other than Thermo Pride filter racks is selected for retention of the filter and/or use of a different filter type is desired, refer to Table 2 below for minimum sizing guidelines for selecting filter for the unit.

Filter Type	Maximum Air Velocity (ft/min)	Model Number OHC*
*Thermo Products Supplied Permanent	600	384 in ²
Standard Permanent	500	461 in ²
Disposable	300	768 in ²

Table 2: Minimum Required Filter Area (in square inches)

* The Thermo Products supplied filter can be cut to size to fit other filter retention systems as long as the minimum size requirement is met.

F. LIMIT POSITION AND LOCATION:

⚠WARNING: The predetermined limit locations on all of the Thermo Pride oil fired furnaces have been tested and approved by Thermo Products, LLC. Any attempt to relocate these safety controls or replace these safety controls with a control that is not approved, or is incompatible, may result in personal injury, substantial property damage or death.

G. BURNER INSTALLATION:

NOTICE: This furnace comes with a Riello BF3 burner preinstalled from the factory. If there is a need to remove the burner prior to installation or during service, the following explains how the burner is inserted and mounted.

The oil burner is mounted on three stud mounting bolts on the mounting plate covering the opening in the front of the heat exchanger. This unit is designed with a pre-positioned chamber. There is no insertion adjustment necessary. The unit requires only the mounting of the burner. Insertion is pre-determined. The top panel is removable by taking out the four screws for easy access to the burner and the piping. Replace this panel prior to operating the furnace.

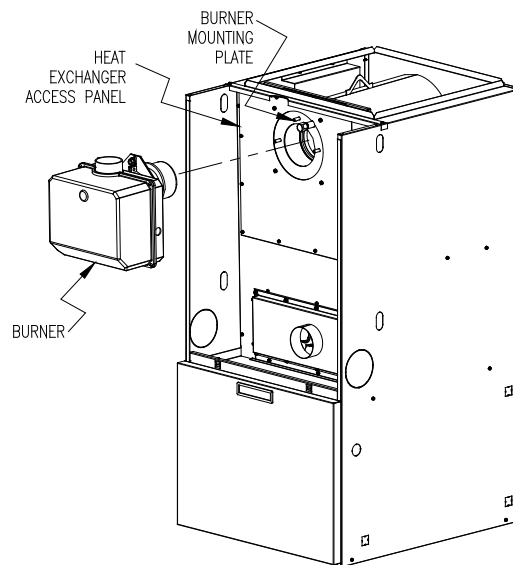

Fig-7

H. BURNER SPECIFICATIONS AND APPLICATIONS:

The BF3 Riello flame retention oil burner is the only oil burner that can be used on the OHC.

FURNACE MODEL	THERMO PRIDE'S BURNER SPEC NO.	AMULETTE	RIELLO BURNER MODEL & TUBE LENGTH	MAXIMUM NOZZLE SIZE**	SHIPPED NOZZLE SIZE	OIL PUMP PRESSURE (PSIG)
OHCFA072DV4R	C8511373	380789	BF3-4.5"	0.50X60° H	0.50X60° H	145

Table 3: Riello burner specifications

THE NOZZLE SIZE GIVES THE NOMINAL FLOWRATE, IN GPH, FOLLOWED BY THE SPRAY ANGLE, IN DEGREE'S, AND THE SPRAY PATTERN, EITHER "H" FOR HOLLOW CONE OR "S" FOR SOLID CONE. FOR EXAMPLE, A NOZZLE RATED AT 0.65 GPH @ 100 PSIG THAT PROVIDES AN 80° SPRAY ANGLE AND A HOLLOW SPRAY PATTERN WOULD BE ABBREVIATED IN THE TABLE AS "0.65 X 80°H".

For more specific burner information, contact:
Thermo Products Tech Service Department

OIL NOZZLE CAPACITY CHART			
UNITS	NOZZLE SIZE (GPH)	EQUIVALENT HEAT INPUT RATE* (BTU/HR)	EFFECTIVE HEATING CAPACITY** (BTU/HR)
	Riello		
OHCFA072DV4R***	.50	75,000	72,000

Table 4: Oil nozzle capacity

Rate shown achieved with 145 PSIG pump pressure for Riello.

* Based on #2 domestic heating fuel oil having heating value of 140,000 BTU per gallon.

** Based on AFUE of 95%.

*** It is recommended to use Low Sulfur or Ultra Low Sulfur #2 fuel oil or lighter.

For more specific burner information, specifications or service information, reference the training manual enclosed with each Riello burner or contact:

Riello Corporation of America,
5 Pond Park Road Hingham, Massachusetts 02043
Phone: (617) 749-8292

I. OIL TANK AND PIPING:

⚠WARNING: All local codes and ordinances take precedence with regard to selection and installation of oil storage tank and oil supply (and return) lines. In the absence of local codes, all tanks and lines must be selected and installed according to the instructions in this manual and the Standard for the Installation of Oil-Burning Equipment, NFPA 31-1997, or the latest edition.

In situations where the oil storage tank is installed at the same level with, or above, the burner, a single oil supply line run from the oil tank to the burner will usually be adequate. No return line will be required. If the oil tank is installed below the burner and the lift exceeds approximately 8-ft, an oil supply line and an oil return line are recommended.

Refer to the Standard for the Installation of Oil-Burning Equipment, NFPA 31-2001, and the oil burner operating instructions for detailed information on oil storage tank and oil supply/return installation.

NOTICE: We recommend installing a high efficiency oil filter, in the oil supply line, capable of filtering 10 to 20 micron diameter (or preferable smaller) particles from the fuel.

If available, **the use of ultra-low or low sulfur (less than 0.0015% S and 0.05% S, by weight, respectively), no. 2 fuel oil is highly recommended.** Low sulfur fuel oil can help to significantly reduce instances of blockage and corrosion of the oil burner fuel delivery system (especially the nozzle), the furnace heat exchanger, and the flue gas venting system. Air pollutants emitted by the furnace and the typical malodorous smell of oil combustion will be reduced.

1. The use of black steel pipe and malleable iron fittings or heavy wall copper is recommended for all fuel oil service lines. **Never use galvanized steel piping or fittings for any fuel oil lines.**
2. Where practical, provide rigid supports for the piping.
3. If the piping size in a run must be reduced, use reducing couplings only. Avoid the use of reducing bushings.
4. Remove all pipe thread burrs and inspect the pipe for dirt or other foreign material prior to connecting. If present, remove any deposits in the piping and discard any excessively corroded piping.
5. A readily accessible, design-certified, manual oil shutoff valve, with a non-displaceable rotor member, shall be installed in the fuel oil supply piping within 6 feet of the appliance.
6. A pipe union, or flanged connection, shall be provided downstream from the manual oil shutoff valve to permit removal of the appliance oil pump. Pipe unions must be the ground joint type or flanged-jointed using a gasket resistant to the corrosive action of fuel oils.
7. Pipe dope or thread sealant design-certified to be resistant to the action of fuel oils should be used on all threaded joints. Thread sealant should only be applied to the male member of a joint. The first two threads on the end of the male member of each pipe joint should be clean and free from thread sealant.
8. Connection of the oil supply and return line piping to the appliance should be made from the left-hand side of the burner, facing the burner compartment cover.
9. When copper is to be used for fuel oil supply lines, use of continuous runs of heavy wall copper tubing is recommended. **Avoid running tubing against any type of heating unit and across ceiling or floor joists.** If possible, install the tubing under the floor.
10. Where tubing is used for fuel oil supply lines, insure the tubing contains no kinks, sharp bends, or collapsed regions where the inside cross-sectional area of the tube is greatly reduced. These will excessively reduce the flow of oil.
11. Flared fittings should be used at all tube joints, when tubing is used for fuel supply lines. **Do not use compression fittings.** Avoid the use of tube fittings in inaccessible locations.

The BF3 burner has been factory set-up for a two pipe system. This means the burner has been equipped with a by-pass plug. To aid in the installation, twin street-ells have been applied to the burner oil connections. It is recommended that the installation remain a two-pipe set-up. If there are issues of difficulties in running a return line to the oil tank it is permissible and recommended to install a de-aerator such as a Tigerloop Brand for this application. This will ensure there to be no lift issues or problems with the installation and eliminate the need to run a return pipe back to the tank.

Burners are equipped with a single-stage, fuel pump. This type of fuel pump, when connected with a supply line only, is satisfactory where the fuel supply is level with, or above the burner thus permitting gravity flow of oil to the burner. If the tank is above the burner, and gravity oil feed to the burner is permitted, a single line system may be used. The line should have a gradual slope downward of approximately 1/2 inch per foot, or more, from the tank to a point directly below where it is connected to

the pump. Pitching the line upward toward the tank will help prevent the formation of air pockets in the line.

J. ELECTRICAL WIRING:

⚠WARNING: This appliance must be grounded in accordance with local codes, or in the absence of local codes, with the National Electrical Code, ANSI/NFPA 70-1999, or the latest edition.

Electrical Connections

NOTICE: All field wiring must conform to local, state, and national installation codes.

A disconnection switch equipped with overcurrent protection rated at 15 A. (e.g. a time delay-type fuse or inverse time, circuit breaker) should be installed in the service line for shutting down and protecting the furnace and electrical system.

Since the furnace is entirely pre-wired at the factory, it is only necessary to connect the building electrical service lines to the two (2) pigtail wires extending from the 2x4 junction box. The fan timer board is mounted inside the furnace blower compartment. The service lines to the furnace should be no smaller than 14 Ga., insulated copper wire with a temperature rating of 60⁰C, or greater.

Connect an equipment ground wire to the furnace at the 2x4 junction box. If wiring is run through metal electrical conduit, it may not be necessary to run a separate equipment ground wire. Consult local codes and authorities for specific minimum requirements.

A two (2) wire connection to the room thermostat from the fan timer board is also necessary. This is typically a low voltage (24 VAC) circuit. Consult the National Electrical Code, ANSI/NFPA 70-2002 or latest edition, for guidelines for proper wiring methods and materials for this circuit.

Refer to the electrical diagrams contained in Appendix B of this manual for an electrical schematic, a connection diagram, and operating instructions.

Room Thermostat

A room thermostat is **not** furnished with this furnace. However, a thermostat is required to properly operate the furnace control system in a typical residential heating application.

The room thermostat should be located on an interior wall in the natural circulating path of the room air.

The thermostat should **not** be installed in a location where it is directly exposed to,

- cold air infiltration, i.e. drafts from outside openings such as windows and doors,
- air currents produced by supply air registers, and
- heat from a nearby source, such as a fireplace, electrical appliances, lamps, solar radiation, a wall enclosing warm air ducts, a chimney, or a flue gas vent.

Model	Voltage/Frequency No. of Phases (V/Hz/Ph)	OHC Full Load Current (Amps) @ 120 VAC	Supply/Return Air Blower Full Load Current (Amps) @ 120 VAC	Oil Burner Assembly Full Load Current (Amps) @ 120 VAC	Maximum Time Delay Type Fuse or Inverse Time Circuit Breaker Size (Amps)	Minimum Recommend ed 75 deg. C. Copper Power Wiring Size (AWG)
OHCFA072DV4	120/60/1	11.45	7.15 ECM	2.5	15	12

Table 5: Typical Electrical Requirements

Post-Purge Timer:

This furnace is equipped with a post-purge timer located in the blower compartment on the control panel. It is pre-set at the factory for a 4 minute post-purge. This is designed to ensure that no residual heat or combustion odors permeate back into the home. The 4 minutes has been deemed sufficient, however if you experience the need for a longer post-purge, the device has 3 selectable settings; 4 minutes, 5 minutes and 7 minutes. By simply turning the knob to one of the remaining selections the post-purge time will be effected.

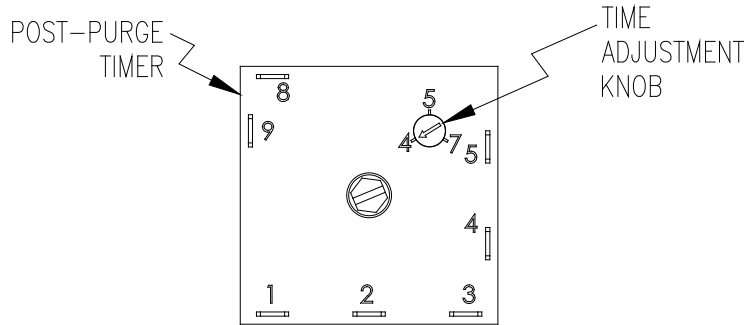

Fig-7A Post Purge Timer

Electronic Air Cleaner (EAC) and Humidifier Installation:

The fan timer on this unit has designated terminals to control the operation of an electronic air cleaner and/or humidifier. These terminals provide line voltage for the control of these accessories, refer to Figure 8 on the next page. Connection between EAC and N6 provides a switched 115 vac to power an electronic fan cleaner. The same-switched 115 vac is available between Fan and N7 and may be used in conjunction with a humidistat to control a humidifier. These terminals are energized whenever the blower is active.

OHCFA072DV4

ALTERATIONS REQ'D FOR A/C @ DESIGN EXTERNAL STATIC PRESSURE		
COOLING UNIT	Recommended HTG Speed	Recommended CLG Speed
24,000	Med Low	Low
30,000	Med Low	Med Low
36,000	Med Low	Med
42,000	Med Low	Med High
48,000	Med Low	High

Speed Tap\ Static Pressure	Furnace Airflow (CFM) vs. External Static pressure (in. WC.)						
	0.1	0.2	0.3	0.4	0.5	0.6	0.7
Low	1018	959	917	857	794	706	638
ML	1180	1140	1075	1137	992	952	887
Med	1311	1276	1244	1202	1146	1122	1062
MH	1554	1524	1489	1440	1403	1360	1316
HIGH	1718	1688	1656	1620	1583	1554	1524
	Furnace Motor Current Draw (Amp/Watts) vs. External Static pressure (in. WC.)						
Low	1.8/141	1.9/148	2.0/154	2.0/160	2.2/168	2.2/175	2.3/181
ML	2.6/207	2.7/213	2.8/222	2.8/228	2.9/238	3.0/245	3.1/257
Med	3.4/283	3.5/293	3.6/301	3.7/310	3.8/318	3.9/326	4.0/334
MH	5.1/442	5.2/451	5.3/460	5.4/466	5.5/480	5.6/487	5.7/496
HIGH	6.8/593	6.8/603	7.0/613	7.1/624	7.2/631	7.3/642	7.9/655
Speed Tap\ Static Pressure	Temperature Rise vs. External Static pressure (in. WC.)						
	0.1	0.2	0.3	0.4	0.5	0.6	0.7
Low	69	70	72	77	83	93	103
ML	56	58	61	64	66	69	74
Med	50	52	53	55	58	59	62
MH	42	43	44	46	47	48	50
HIGH	38	39	40	41	42	42	43

Low= Red
 Med Low= Purple
 Med= Blue
 Med Hi= Yellow
 High= Black

Table 6: Blower Motor Speed Setup

M. BLOWER CONTROLLER INFORMATION FOR ECM MOTOR

TERMINAL DEFINITIONS & FIELD WIRING

Burner Harness Connector P1

- Pin 1- Limit switch connector.
- Pin 2- 120 VAC Line connection.
- Pin 3- Burner pilot contact.
- Pin 4&5- 120 VAC Neutral connections.
- Pin 6- Burner pilot contact.
- Pin 7&8- From oil primary control.
- Pin 9- Limit Switch Input (LSI).

Field Wiring to Burner

	Pilot (Tstat)	Neutral	Line
Harness Wires	Yellow Wires	White	Red
Riello Connections	T-stat terminals	White	Black

Thermostat / Humidistat connections

- "C" Common / ground
- "W" Thermostat call for heat
- "R" 24 VAC to thermostat
- "G" Thermostat call for fan
- "Y" Thermostat call for cool
- "DEHUM" Humidistat call for dehumidification (TXV systems ONLY)

Male quick connect terminals.

- "S1-3" 120 VAC Hot
- "N1-7" 120 VAC Neutral
- "EAC" Electronic Air Cleaner (120 VAC) connection
- "FAN" Fan On Signal
- "X" 24 VAC from transformer
- "C" 24 VAC common from transformer
- "CC" Compressor Contactor
- "CC_COM" Compressor Contactor Common
- "LOW" Continuous Blower Speed
- "HEAT" Blower heat speed tap
- "COOL" Blower cool speed tap

Inputs

Power supplies

Line voltage is applied between the "S1" and "N1" quick connect terminals. 24 VAC Class II Transformer secondary voltage supplied to X and C

Limit switch

The 120 VAC optically isolated limit switch input is connected on pin P2-1 & 9. Refer to the Heat Mode section for the control operation.

Thermostat call for heat "W"

24 VAC thermostat input. A call for heat is recognized when the thermostat connects "W" to "R". This input has an indicator LED that will light when the control receives a call for heat. Refer to the Heat Mode section for the control operation.

Thermostat call for cool, “Y”

24 VAC thermostat input. A call for cooling is recognized when the thermostat connects “Y” to “R”. This input has an indicator LED that will light when the control receives a call for cooling. Refer to the Cool Mode section for the control operation.

Thermostat call for dehumidification “DEHUM”

24 VAC thermostat input. A call for dehumidification is recognized when the humidistat connects “DEHUM” to “R”. This input has an indicator that will light when the control receives a call for dehumidification. Refer to the Cool Mode section for the control operation.

Thermostat call for fan “G”

24 VAC thermostat input. A call for fan is recognized when the thermostat connects “G” to “R”. This input has an indicator LED in that will light when the control receives a call for fan. Refer to the Fan Mode section for the control operation.

Outputs

PSC Control

The control shall control a five-speed indoor blower motor. Rating shall be 10 FLA, 30 LRA @ 120 VAC. Connections are made via 0.250 x 0.032” male quick connect terminals labeled “HEAT”, “COOL”, and “LOW”. “HEAT” is energized when the heat speed blower is to run. “COOL” is energized when the Cool speed blower is to run. “LOW” is energized during a call for fan is received or a call for dehumidification is received.

Oil Burner

Control

The control provides dedicated contacts to operate the T-T input of an oil primary control. Rating shall be class 2 – 24 VAC pilot duty @ 24 VAC (<200mA).

Power

The switched 120 VAC power from the LIMIT switch passes through the board between Pins 1 & 2 of connector P1.

Compressor contactor

The control provides switched 24VAC to operate a compressor contactor. Rating shall be class 2 – 24 VAC pilot duty @ 24 VAC (<200mA).

EAC (electronic air cleaner)

The control provides a 120 VAC output for an electronic air cleaner. This output is energized whenever the fan motor is energized (either low, heat or cool speed). Connection is made via male quick connect terminal labeled “EAC”.

Humidifier

The control provides a 120 VAC output for a humidifier. Connections are made to a male quick connect terminal labeled “FAN”. The control does not switch this output, it provides a pass-through connection from P1-7 from the switched primary voltage of the Burner Module.

Status LED

A red LED is provided to indicate any thermostat input has been recognized by the microprocessor on the control. See Diagnostic Features for a function description of operation.

Thermostat Input LEDs

Four green LEDs are placed beneath their respective thermostat connections (W, Y, G and DEHUM) and operate whenever a call is present. See Diagnostic Features for a function description of operation.

Operating Modes

Standby Mode

All outputs are off and the control is waiting for a thermostat demand. The thermostat inputs, and limit switch are continuously monitored. The control initiates action when a thermostat call is received or limit switch opens.

Fan Mode

A call for fan (“G”) is received from the thermostat. If no other mode is calling for blower operation, the control will operate the fan relay (K4) and power the “Low” blower speed terminal. The fan mode will be operated as long as the “G” input is calling and neither the Heat mode nor the Cool mode is calling for blower operation. When the Heat and Cool modes call for blower operation, their respective outputs will take precedence after their respective turn-on time delays have expired.

Cooling Mode

A call for cool (“Y”) is received from the thermostat. If the heat mode is not active or the anti-short cycle delay is not in effect, the control will energize the “CC” terminal and after a 10 second power demand conservation delay energizes the “COOL” speed blower terminal.

When the call for cool is satisfied, the “CC” terminal is de-energized and the cooling off delay of 45 seconds is started. Forty-five seconds later the “COOL” speed blower terminal is de-energized and the control reverts to Standby Mode.

Dehumidification Operation

If a call for dehumidification is received while the Cool Mode is active, blower speeds will be reduced. The PSC “COOL” blower speed terminal (1158-100 model only) will be de-energized and “Low” blower speed will be energized.

Anti-Short Cycle Operation

To prevent compressor short cycling, a call for cooling will be ignored for four minutes after the termination of any cooling call. The anti-short cycle delay is also in effect at power-up.

Heat Mode

When a call for heat (“W”) is received from the thermostat, if the “Cool” mode is not already active, the “T-T” terminal is energized and the blower on delay is started. The on-off pattern of DIP switch SW2 (positions 1 and 2) select one of four blower on delay values (see Table 7). When the delay time has elapsed, the “HEAT” blower speed is energized. The control remains in steady heat mode until the thermostat is satisfied. When the call for heat signal is removed, the “T-T” terminal is de-energized and the blower off delay is started. The on-off pattern of DIP switch SW2 (positions 3 and 4) select one of four blower off delay values (see Table 7). When the delay time has elapsed, the “HEAT” blower speed terminal is de-energized.

Motor Blower Speed

Three interconnected blower speed outputs are provided. A “G” call for fan will provide power to the LOW speed tap only. A “W” heat call will provide power to the Heat speed tap only. A “Y” cooling call will provide power to the Cool speed tap only.

In the case of thermostat calls for “Y” and “W” together, blower speed selection will be determined by the input that was first initiated. In the case where the control is in a cooling mode with both “Y” and “W” inputs energized and then the “Y” input is removed, the cooling blower off time will be executed prior to the control switching into a heating mode. In the case where the control is in a heating mode with both “Y” and “W” inputs energized and then the “W” input is removed, the heating blower off time will be executed prior to the control switching into a cooling mode. In the case where a call for fan “G” already exists and either a “W” or a “Y” call is initiated, the blower speed will switch to the respective “W” or a “Y” speed following the blower on delay for that call.

The speed taps are interconnected and interlocked, only one speed may be powered at any one time. When a speed is to be operated, the speed select relays are operated to select the path to the motor tap and then the enable relay is operated to switch the operating power to the selected motor speed tap. If the speed of the running motor is to be changed, first the enable relay removes power from the motor, the new speed is selected and then power is restored to the motor.

Blower On and Off Delays

Four Heat blower on and four blower off delays are selected by two dip switches for each function. Refer to Table 7 for specific delay values.

DIP SWITCH 2 SECTION STATE				BLOWER DELAY TIMES		
1	2	3	4		ON - SEC	OFF - MIN
OFF	OFF				30	
ON	OFF				60	
OFF	ON				120	
ON	ON				240	
		OFF	OFF			2
		ON	OFF			4
		OFF	ON			6
		ON	ON			8

Table 7: ON and OFF Blower Delay Time Switch Settings

TROUBLE SHOOTING

DIAGNOSTIC FEATURES

The control board is equipped with 4 green Input Status LEDs and 1 red Board Status LED. These are intended to provide a quick view into furnace performance without requiring a voltmeter.

The green Input Status LEDs are driven by the “Y”, “W”, “G”, and “DEHUM” inputs and are located directly below those inputs. They will light to indicate the presence of these signals.

The red Board Status LED has two functions:

It will light when the board recognizes a valid input signal and will stay lit until all valid signals are removed. This is intended to show that the board is functioning and able to respond to input signals.

It will flash rapidly while 120VAC is missing from the LIMIT switch. This is intended to give a quick visual indication of the High Limit switch.

N. STARTUP PROCEDURES:

A. Heating System

1. Initial Startup:

⚠WARNING: Turn off power to furnace. Before the oil piping system is placed into service, it must have been leak tested by a qualified heating contractor.

⚠WARNING: For initial start-up of the appliance after installation, it may be necessary to purge the air out of the oil line. A qualified heating contractor should do this.

Review the following items before the initial startup. It may be helpful to review the **Sequence of Operations** in **Section VIII** of this manual, also.

- a. Check all wiring for loose connections and proper hook-up. Refer to the connection diagram.
- b. Leak test all field oil piping connections. Generally, this will involve pressurizing the oil piping with air while being careful to isolate the oil tank at high test pressures. **A qualified heating contractor should perform this service.**
- c. Check to see that the vent terminal is correctly installed and the terminal openings are clear and free from blockage.
- d. Make sure the air filter is in place and relatively clean of dirt and debris.
- e. Make sure the thermostat is set in the heating mode of operation.

For Your Safety Read Before Operating:

⚠WARNING: If you do not follow these instructions exactly, a fire or explosion may result causing property damage, personal injury or loss of life.

- This appliance does not have a pilot light. It is equipped with an ignition system that automatically lights the burner. Do not attempt to light the burner by hand.
- Do not use this appliance if any part has been under water. Immediately call a qualified service technician to inspect the appliance and to replace any part of the control system and any oil control that has been under water.

Operating Instructions:

- i. **STOP! Read the safety information above.**
- ii. Set the thermostat to the lowest setting.
- iii. Turn off all electric power to the appliance.
- iv. This appliance is equipped with an ignition system that automatically lights the burner. Do not try to light the burner by hand.
- iv. Rotate the manual oil shutoff valve to the "ON" position.
- vi. Turn on the electric power to the appliance.
- vii. Set the thermostat to the desired setting.
- viii. If the appliance will not operate, call your qualified service technician or oil supplier.

To Turn Off Oil to Appliance:

- i. Set the thermostat to the lowest setting and set the operating mode switch to "OFF".
- ii. If service is to be performed, turn off the electrical power to the appliance.
- iii. Turn the manual oil shutoff valve to the "OFF" position.

2. Adjustment of Burner Combustion:

⚠CAUTION: Do not run the oil pump dry for more than five minutes, as irreparable damage may result.

NOTICE: Read the burner operation and service instructions Manual before continuing.

To initially adjust and successfully service the oil burner in the appliance heating section, the following test instruments are required:

- A smoke density measuring and rating device,
- A carbon-dioxide (CO₂) or oxygen (O₂) analyzer,
- A flue gas temperature measuring device (e.g., thermocouple or thermistor probe with readout device),
- An analog or digital multimeter, and
- An oil pressure gauge capable of reading 0-150 PSIG.

3. Sequence of Operation for the OHC:

The OHC has been designed to operate under a negative over-fire pressure. This is accomplished in part by the coordinated set-up of the Riello BF3 burner and the inducer blower which is installed in the ventor assembly. The two devices work together for proper operation. The sequence of operation is as follows:

1. Call for heat TSTAT closes sending 24 volts to "W".
2. The 24 volt relay closes sending 115v to the inducer in the ventor assembly.
3. The inducer comes up to speed and provides flow and pressure which closes the pressure switch.
4. Upon this pressure switch closing, T & T are closed to bring on the burner.

To initially fire the oil burner, proceed in the following manner:

- a. Turn the disconnecting switch, which provides power to the appliance, to the "OFF" position.
 - b. Set the room thermostat above room temperature.
 - c. Verify the oil tank is filled with sufficient fuel oil to operate the appliance.
 - d. Open all valves in the oil supply line to the burner.
 - e. Remove the burner compartment cover from the appliance.
 - f. Turn the disconnecting switch to "ON".
 - g. Prime the pump to remove air in the oil supply line.
 - See Riello Burner Manual included.
 - h. The burner has been installed with the pump pressure pre-set to 145 psi, the turbulator set at 3 and the air gate set to 3. These are general preliminary settings and adjustments should be made to ensure clean combustions for this application.
 - i. Replace burner cover.
 - j. The air adjustments can be made by removing the plastic plug on the top right side of the cover. Turning the screw counter clockwise will increase the amount of combustion air. Turning the screw clockwise will decrease the amount of combustion air. A small ¼ " diameter hole should be drilled in PVC just outside the furnace to insert the combustion sample hose. **Remember to seal hole after acquiring flue gas sample.**
5. Burner now operates and can be properly set-up for clean combustion.
 6. Blower comes on after delay on time.

Notice: To achieve proper combustion instruments must be used to secure CO₂ or O₂ readings and smoke samples.

Notice: Heat exchanger oil will burn off on initial firing creating an unpleasant odor. To prevent this odor from occurring more than once, it is suggested the heating section be allowed to run for 30 minutes, or until odor has dissipated.

- k. **CARBON DIOXIDE (CO₂) OR OXYGEN (O₂):** Take a CO₂ sample from flue passageway. It is possible to achieve readings of up to 14% CO₂ (or 2% O₂), but it is recommended to have a lower CO₂ (or higher O₂) reading with zero smoke measured. To achieve a lower CO₂ reading, open the air plate on the burner until zero smoke is measured. A CO₂ of 11-1/2% is recommended.

For example, if a 13% CO₂ (or 3.5% O₂) is recorded at a trace of smoke, open the air shutter until zero smoke is measured with a 11-1/2% CO₂ (or 4.5 O₂).

Adjustment of the burner to achieve a slightly lower CO₂ reading is recommended, although it slightly reduces combustion efficiency, to keep the heating system within normal operating conditions though external conditions may vary. Some "out-of-spec" conditions which may adversely affect burner performance are, low oil supply temperature, dirty (contaminated) oil, low heating content (BTU/gal) oil, cold heat exchanger surfaces, and downdraft conditions. By adjusting the burner in this manner, an operational tolerance is established by allowing the burner to function well, even under less than ideal conditions. This results in less service and maintenance during a heating season.

- l. Removing the draft over fire cap allows for flame inspection and over fire pressure measurement. The over fire pressure will be negative and will vary depending on the final combustion set-up. If the over fire pressure is positive, shut down the burner and make certain the inducer is operating and that the vent system meets the installation requirements on page 9 and 10.
- m. Temperature rise is equal to the supply air temperature minus return air temperature. Under steady state operating conditions, the temperature rise across the heating section should be approximately between 55⁰F and 85⁰F. A higher temperature rise will slightly lower the heating efficiency.

The supply air temperature should be measured in the supply air trunkline approximately 12 inches downstream of the supply air outlet of the appliance.

NOTICE: Minimum temperature rise is 55⁰ F.: maximum temperature rise is 85⁰ F.

NOTICE: Minimum return air temperature is 55⁰ F.

- n. After final adjustments are completed, tighten all screws to fix the positions of the burner air band and replace the plastic plug.
- o. Check for the presence of oil leaks. Correct any leaks found.
- p. Reassemble the burner compartment cover and replace the draft pipe cap.
- q. Start and stop the unit several times while checking for proper ignition of the burner. The flame should ignite and stabilize without any significant rumbles or pulsations.

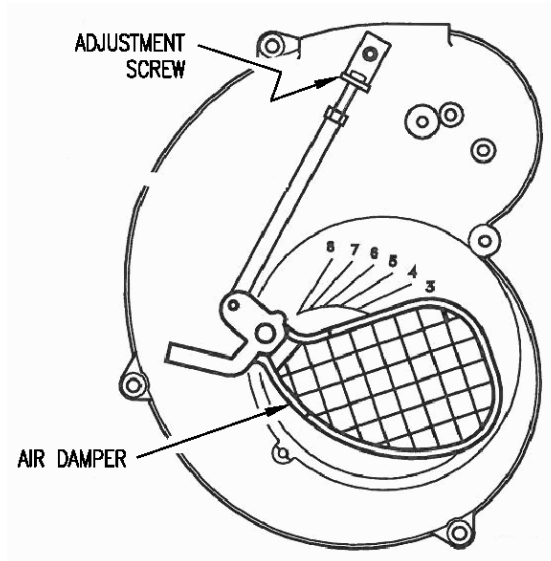

Fig-9

NOTICE: To achieve proper combustion and the efficiencies listed in sales brochures, instruments must be used to secure CO₂ or O₂ readings.

3. Adjustment Of Heat Input Rate:

This appliance was shipped from the factory with one, fixed, main burner nozzle sized to produce the input rate using no. 2 fuel oil at 145 psi. The input rate cannot be increased.

The main burner oil nozzle for this unit was selected based upon the following assumed characteristic values of the fuel oil suitable for use with this appliance design:

1. For no. 2 distillate fuel (domestic heating) oil having a higher heating value of 140,000 BTU per gallon and a specific gravity of 0.88 @ 60°F. (or "gravity" of 30° API @ 60°F.).

4. Setting Supply Air Temperature Rise:

⚠WARNING: To avoid injury from moving parts or electrical shock, shut off the power to the appliance before removing supply air blower compartment door and servicing this appliance.

The OHC is designed and wired at the factory for a blower speed during heating that should result in an approximate temperature rise of 60°F. The temperature rise through the heating section, for any given blower speed, may vary depending on a number of factors. A few of these factors are variations in, the actual resistance of the duct system to airflow at any time, the return air temperatures, and the fuel oil heating value.

Also, fouling of the heat exchanger surfaces will reduce temperature rise. In general, a lower temperature rise through the heating section will result in higher heating efficiency.

Temperature rise = supply air temperature - return air temperature.

After 15 to 20 minutes of continuous operation, the temperature rise through the furnace must fall within a range of 55° to 85° F. If the outlet or supply duct temperature is too high, check to make sure the return air filter is clean, the return air registers are free from obstruction, the outlet registers are properly adjusted and clear, and the supply and return air ducts are open. The circulating air blower is not moving enough air if the supply air temperature is still too high. Before proceeding further, turn off the power supply to the appliance and remove the vestibule cover. The speed of the blower must be increased by changing the switch setting on the control board, please refer to Table 6.

5. Checkout Procedure:

Before any system of oil piping is finally put into service, it shall be carefully tested to assure that it is "gas-tight", as indicated in the **Heating System Initial Startup** section of this manual.

NOTICE: All controls on the unit should be checked for proper functioning prior to the qualified service personnel leaving the job site. Specifically the following should be checked:

- a. With heating system in normal heating operation, check to make certain blower will start and stop automatically under control of the indoor thermostat.
- b. Check safety limit control as follows:
 - i. Shut off incoming power.
 - ii. Block return air opening or disconnect blower motor leads.
 - iii. Restore power to appliance.
 - iv. In the heating mode, set the thermostat above room temperature producing "a call for heat".
 - v. When high air temperatures are reached within the heating section, the high limit control should act to shutdown the burner.
 - vi. Shut off the electrical power.

IMPORTANT: Remove blockage or reconnect blower motor and restore power.

- c. Make certain the thermostat will automatically start and stop the appliance.

NOTICE: Heat exchanger oil will burn off on initial firing creating an unpleasant odor. To prevent this odor from occurring more than once, it is suggested the heating section be allowed to run for 30 minutes, or until odor has dissipated.

III. USERS INFORMATION SECTION

A. OIL SUPPLY: Do not allow the fuel tank to run completely empty. During the summer, keep the tank full to prevent condensation of moisture on the inside surface of the tank. If the fuel tank runs completely dry, it may be necessary to purge the lines of trapped air. Contact a qualified technician to bleed the lines and restart the burner.

OIL SUPPLY VALVE: Turn the oil supply valve off if the burner is shut down for an extended period of time.

B. INSPECTION AREAS

VESTIBULE: The furnace vestibule area or burner compartment should be inspected by removing the front door of the furnace and looking for signs of excessive heat such as discoloration of components materials damage, from rust or corrosion, soot or carbon build-up.

EXTERIOR OF FURNACE: The furnace exterior should be inspected for signs of excessive heat such as discoloration of materials and damage from rust or corrosion.

VENT PIPE: The furnace vent pipe should be inspected for signs of holes in pipe, and leakage around seams in pipe, indicated by soot or condensate streaks.

⚠ CAUTION: DO NOT ATTEMPT TO MAKE REPAIRS YOURSELF!

⚠ WARNING: The area around the furnace should be kept free and clear of combustible liquids and material, especially papers and rags.

⚠ WARNING: NEVER burn garbage or refuse in your furnace. Never try to ignite oil by tossing burning papers or other material into your furnace.

⚠ WARNING: Thermo Pride oil furnaces are designed to burn No. 1 or No. 2 distillate fuel oil, and should be of low or ultra-low sulfur content.

⚠ CAUTION: DO NOT ATTEMPT TO START THE BURNER WHEN:

1. Excess oil has accumulated,
2. The furnace is full of vapors
3. The combustion chamber is very hot.

IF ONE OR MORE OF THESE CONDITIONS EXIST, CONTACT A QUALIFIED SERVICE PERSON.

C. STARTING THE BURNER:

1. Turn the main service switch to "OFF" position.
2. Set thermostat substantially above room temperature.
3. Open shut-off valves in oil supply line to burner.
4. Turn service switch to furnace "ON". If burner starts and runs, but stops again on lockout, it may be necessary to bleed the lines or make burner combustion air adjustments. Contact a qualified service person to adjust and start burner.

D. FILTER CLEANING AND LOCATION:

⚠ WARNING: To avoid injury from moving parts, hot surfaces, or electrical shock, shut off the power to the furnace before removing any furnace access doors to service the air filters.

The air filters should be inspected each month and cleaned when dirty. Cleaning the air filters frequently may reduce airborne contaminants from entering the furnace and depositing in the furnace, duct system and home.

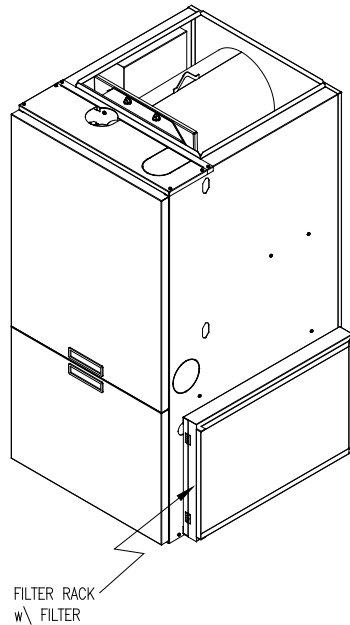

Fig-10

IV. INSTALLER'S INSTRUCTIONS TO USER:

After completing the installation, the installer shall inform and/or demonstrate to the homeowner the following items:

1. The location of these instructions. The instructions must be kept along with instructions for any accessories in the plastic pouch with the appliance.
2. The location and use of the manual oil shutoff valve and appliance electrical disconnecting device. The end user must be instructed to always shut off the electric power to the appliance, before shutting off the oil supply.
3. The sequence of operation of the appliance.
4. The correct operation and maintenance of the appliance, as outlined in the **Homeowner/User Information and Routine Maintenance** section of this manual.
5. That failure to maintain and operate this appliance in accordance with these instructions could result in hazardous conditions, property damage, and bodily injury. It may also void the limited warranty on the appliance.
6. Review with and encourage the user to read the label reproductions and all warnings and instructions outlined on the front cover and in Sections I, II, and III, of this manual.
7. Recommend the user have a qualified heating contractor inspect the entire appliance at least once a year. Inform the user of the frequency of inspection required for each item in the **Dealer Maintenance** section of this manual.

8. Inform the user to maintain adequate clearances around air openings into the appliance housing and not to block or restrict the entrance of air into the condenser coil or the burner compartment air opening.

V. DEALER MAINTENANCE:

SAFETY DURING SERVICING AND INSPECTION
⚠WARNING: Personal injury or property damage could result from repair or service of this appliance by anyone other than a qualified heating contractor. The user may only perform the activities described in the Homeowner/User Routine Maintenance section of this manual.
⚠WARNING: To avoid injury from moving parts, or electrical shock, shut off the power to the appliance before removing blower compartment door and servicing this appliance.
⚠CAUTION: When servicing controls, label all wires prior to disconnecting. Reconnect any removed wires correctly. Wiring errors can cause improper and dangerous operation. Dangerous operation can result in injury or damage.
IMPORTANT: Verify the proper operation of this appliance after any servicing is performed.

A qualified heating contractor should perform the following maintenance procedures at the beginning of each heating season. Correct any deficiencies at once.

A. GENERAL INSPECTION:

⚠WARNING: Shut off oil and disconnect power before continuing with this inspection.

1. Vent tee - Visually inspect the terminal for restrictions, loose or missing fasteners, external damage, and carbon build-up. Clean the vent terminal if necessary. Repair any minor damage. If necessary, replace a severely damaged vent tee.
2. Burner – Visually check the burner, and below the burner, for indications of oil leaks. Correct any, if found. Remove the burner and gun assembly and measure the ignition electrode gap. It should be set to 5/32 inch. Adjust it, if necessary. Clean any accumulation of dust, dirt, or debris from the air shutter or air band openings. If necessary, clean housing and blower wheel with a damp cloth. Use a vacuum to remove any lint or dust from motor assembly. Add a few drops of non-detergent oil to each of the motor lubrication holes.
3. Combustion Chamber - Inspect the liner for deterioration, oil and carbon build-up. If the accumulation of oil or carbon is significant, this is a strong indicator that the burner is out of adjustment. Inspect the burner nozzle for partial blockage and excessive wear. Replace it, if required. Check and adjust oil pump pressure, if needed. Refer to **Initial Heating System Adjustments** section of this manual.

Note: Care must be given to ensure no damage occurs to the chamber insert. (Refer to Figure 11)

4. Heat Exchanger – Visually inspect the heat exchanger for excessive carbon (soot) build-up. Refer to the **Heat Exchanger** section of the manual.

- Visually inspect the 4 heat exchanger tubes for excessive carbon (soot) build-up. Refer to heat exchanger section of the manual.
5. Oil Filter – Replace the supply line oil filter cartridge with a new filter of the same type and rating. Clean the body of, or mounting plate for, the oil filter.
 6. Labels and Markings - Clean all appliance labels, markings, and instruction plates, as necessary, and verify that all are still legible. Any illegible or missing markings must be replaced. Replacements can be obtained by contacting Thermo Products.

B. HEAT EXCHANGER: CLEANING INSTRUCTIONS

⚠WARNING: A qualified heating contractor must clean the heat exchanger.

At least once a year, inspect the heat exchanger for evidence of corrosion, pitting, warpage, deterioration, and carbon (soot) build-up. A layer of soot on the inside of the heat exchanger will act as an insulator and reduce heat transfer, resulting in less heating efficiency.

Also, look for loose or deteriorated gaskets and insulation around the vent pipe, the burner, and accessible areas of the heat exchanger. If this inspection indicates heat exchanger cleaning is necessary, follow the heat exchanger cleaning instructions below.

⚠WARNING: THE HEAT EXCHANGER MUST BE CLEANED BY A QUALIFIED SERVICE PERSON.

It is important to inspect and clean the heat exchanger once a year, or as necessary, to remove any build-up of soot. A layer of soot on the inside of the heat exchanger will act as an insulator and reduce heat transfer, resulting in less efficiency.

1. To clean the heat exchanger, first turn off all power to the unit. Remove the vent connector, the burner, and the burner mounting plates. Then place the heat exchanger cleaning shelf on the 3 bottom bolts as pictured. (See figure 11).
2. With access to the inside of the heat exchanger through the burner area, it is possible to use a long, flexible wire brush and an industrial type vacuum cleaner to remove any soot build-up. **NOTE:** A one inch (outside diameter) vacuum cleaner hose will fit into the tubes.

To vacuum and brush the tubes of the heat exchanger, go through the front openings in both directions, as shown in figure 12 on the next page.

- 3 Remove front cover of heat recovery coil by removing all of the mounting screws. Then carefully pry the cover loose taking care not to bend the cover. Remove a couple of turbulators to give visual inspection of both the tube and tabulator. If excess build-up of soot is found, the secondary coil will need thoroughly cleaned.
4. The entire heat exchanger can be removed from the front by removing the separator. Next remove both side block-off baffles. Then disconnect the drain hose. The heat exchanger will now be able to be pulled straight out of the furnace with the aid of the two back support wheels.
5. The rear coil cover should now be removed as done in #3. Next remove all turbulators. The secondary can now be thoroughly brushed and cleaned.

6. Reassemble the secondary to its original state. Replace heat exchanger, coil block-offs, and separator. Reassemble furnace to its original construction. Remount the burner combustion air inlet. Reconfirm combustion settings.

Replace any damaged or corroded components. All gaskets and insulation must be inspected, and replaced, if they show any signs of damage.

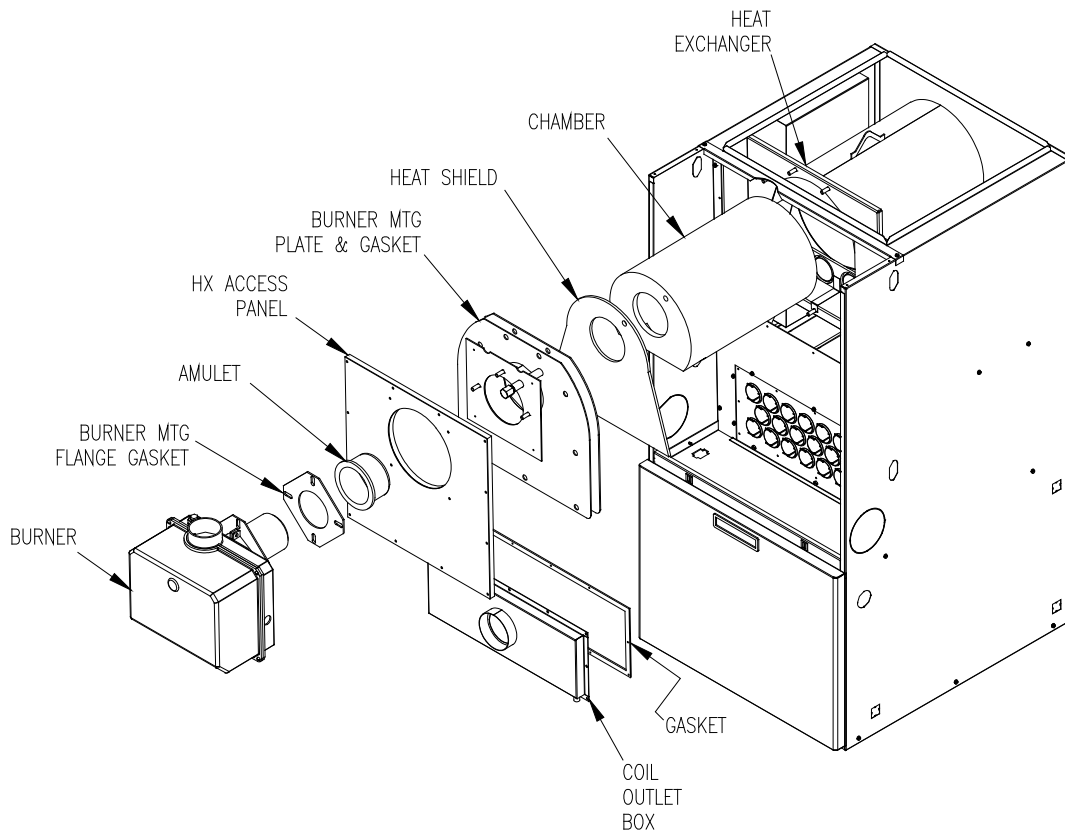

Fig-11

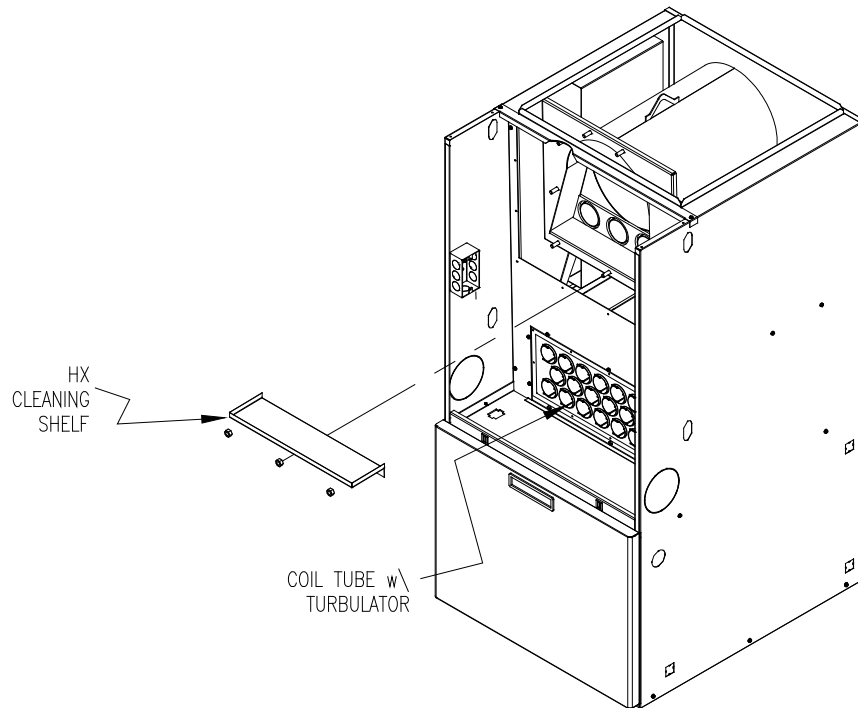

Fig-12

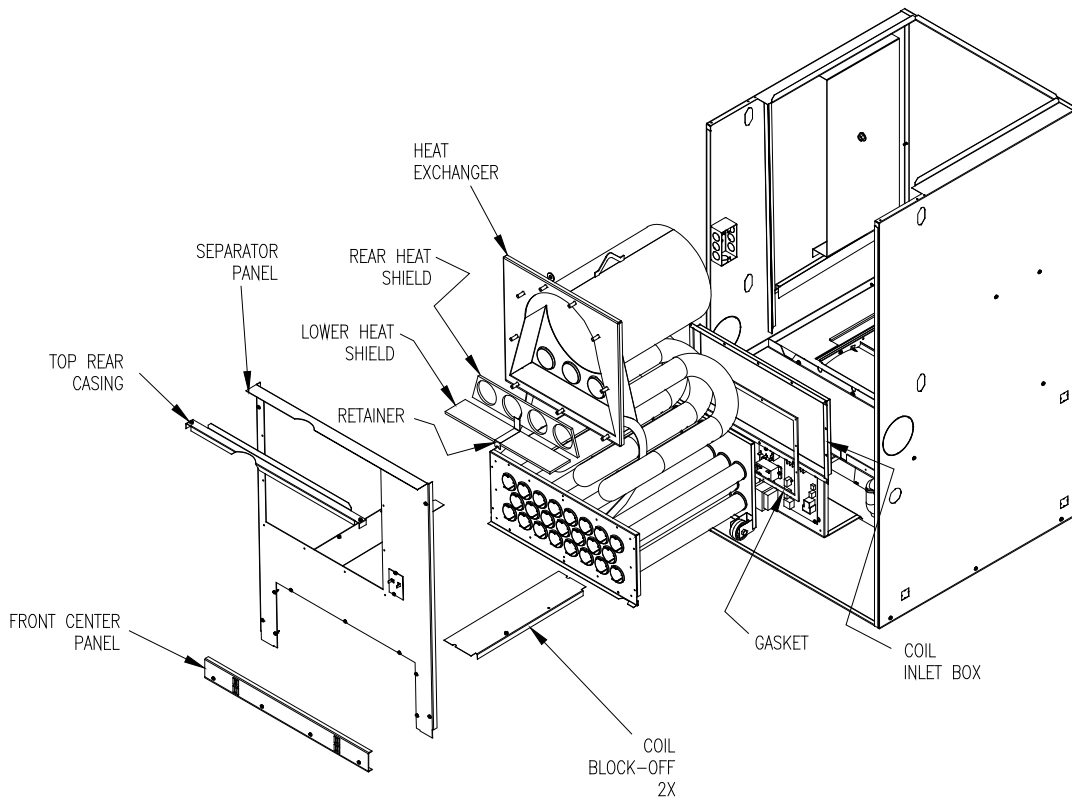

Fig-13

⚠CAUTION: Before troubleshooting, familiarize yourself with the start up and check out procedures

NOTICE: After reassembling the appliance, check for fuel oil leakage from the supply piping.

- a. Check proper operation of the ignition system and for proper combustion.
- b. Observe the main burner flame. If the flame appears strange or abnormal in character, look for a component or components that were not reassembled correctly. If the components have been reassembled correctly, check for a blocked vent, malfunctioning combustion air blower or fuel pump, and partially blocked burner nozzle.

D. ELECTRICAL SYSTEM:

⚠WARNING: When servicing controls, label all wires prior to disconnecting. Correctly reconnect any wires removed during servicing. Wiring errors can cause improper and dangerous operation. Dangerous operation can result in injury or damage.

1. Check all wiring for loose connections and any signs of damage, or unusual wear. Replace any damaged or frayed wiring and tighten any loose connections.
2. Use a voltmeter, or a multimeter, to check for adequate voltage at the field connections when the appliance operating.
3. Use an ammeter, or a multimeter, to check the current draws of the blower motor and burner assembly, to assure they are not exceeding rating label current specifications for each component. Also, refer to Table 5 in the electrical wiring section of this manual for electrical specifications on these components.
4. Check for correct operation and proper settings (if manually adjustable) of all controls.

E. SUPPLY/RETURN AIR BLOWER:

Check in the blower compartment for dust, dirt, debris, and for the presence of insects. Remove any foreign material. Clean the blower wheel, housing, and compartment of dust and lint with a vacuum.

The blower motor has sealed bearings that are permanently lubricated. **The blower motor bearings do not require oil or any type of additional lubrication.**

F. SUPPLY/RETURN AIR FILTER:

The filter rack will be located between the return air plenum and the return air opening on the side of the furnace. This filter should be inspected regularly. When the filter is dirty, it should be cleaned or replaced to assure proper heating/cooling system operation. Follow the cleaning, removal and replacement procedure below.

Filter maintenance procedure:

Shut off the electrical power to the unit. Open the access door. Slide the air filter out of the filter rack. Clean the filter by either vacuuming, rinsing with tap water, hosing, or dipping in an ordinary detergent solution. After cleaning and drying the filter, replace the completely dry filter in the rack. If the filter has a supporting mesh, the mesh side of the filter must be placed towards the furnace.

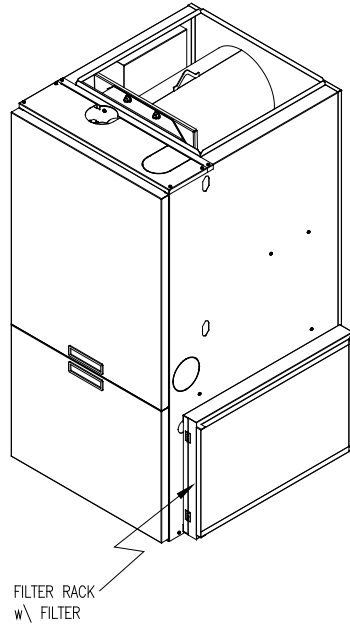

Fig-14

Filter replacement:

To ensure an adequate replacement filter is selected, should the filter require replacing, refer to Table 2, in **Air Filters** section of this manual, for the minimum filter areas required for different types of available filters.

NOTICE: Remind the homeowner of the importance of monthly filter inspections during operation to ensure maximum operating efficiency.

G. EXTENDED APPLIANCE SHUTDOWN:

⚠CAUTION: Do not attempt to start burner when:

- Primary reset has been engaged more than two times.
- Excess oil has accumulated in the combustion chamber or beneath the burner assembly.
- The combustion chamber or the heat exchanger is full of fuel vapor.
- The combustion chamber is very hot.

Should the appliance be shutdown or turned off for an extended period of time, several steps can be taken to help insure a smooth and reliable restart of the heating system.

ON SHUTDOWN:

1. Close oil supply (or manual shutoff) valve.

2. Disconnect all electrical power to the unit.
3. Fill the oil tank to reduce water condensation in the tank.
4. If the shutdown period will exceed one heating season, an oil stabilizer should be added to the oil tank. Consult your oil supplier for recommendations.

ON STARTUP:

1. Have system inspected and started by a qualified heating contractor.
2. Check oil level in tank. If the tank has not been filled with fresh oil, inspect the remaining oil for signs of contamination with water, algae, dirt or other impurities. If excessive, consult your oil supplier for recommendations.
3. Change the oil filter cartridge and clean the canister.
4. Set the room thermostat above room temperature.
5. Open all valves in the oil supply line.
6. Open the inspection cover on the upper mounting plate.
7. Turn on the electrical power to start the burner. If the burner does not start, immediately reset the manual overload switch on the motor (if so equipped) and the safety switch of the burner primary control. Bleed air from the fuel oil line as soon as the burner motor starts rotating. To bleed the fuel pump, attach a clear plastic hose over the vent plug, refer to Figure 15. Loosen the plug and catch the expelled oil in an empty container. Tighten the plug when all the trapped air appears to be purged. If the burner stops during bleeding, wait three to five minutes for the control safety switch to cool. Then manually reset the switch. Continue bleeding the line until the air is completely removed.

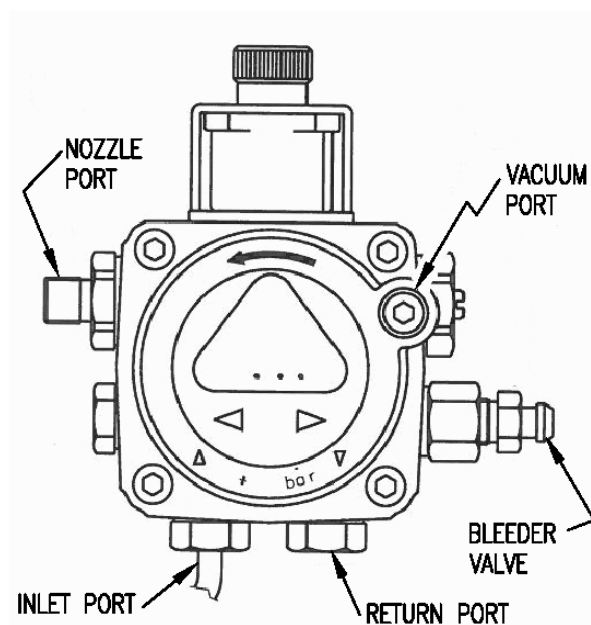

Fig-15

8. Follow the previous **Initial Burner Operation** procedures.

VI. HOMEOWNER/USER INFORMATION AND ROUTINE MAINTENANCE:

⚠WARNING: Never burn garbage or refuse in this appliance. Never try to ignite oil by tossing burning papers or other material into the combustion chamber.

⚠WARNING: Oil-fired appliances produced by Thermo Products are designed for burning No. 2 distillate (domestic heating) fuel oil. Never use gasoline or a mixture of oil and gasoline.

⚠CAUTION: Do not use this appliance if any part has been under water. Immediately call a qualified service technician to inspect the furnace and to replace any part of the control system and any oil control that has been under water.

⚠CAUTION: Should overheating occur, or the oil supply fail to shut off, shut off the electrical power to the appliance, before shutting off the manual oil valve.

⚠CAUTION: The area around the appliance, including the top of the unit, must be kept clear and free of combustible materials, gasoline, and other flammable vapors and liquids.

⚠CAUTION: Do not attempt to make repairs yourself. Contact your local qualified heating contractor.

Under normal conditions, this appliance will operate in either heating or cooling mode, depending upon the mode of operation set at the thermostat. The unit will cycle on and off automatically, as required, to maintain the air temperature within the residence as closely as possible to the thermostat setting. However, in rare cases, the unit may shutdown automatically during a normal cycle or may not operate under seemingly normal conditions.

If the unit will not operate in the heating mode, it may be possible to reactivate the unit by resetting one of the burner controls. To attempt resetting of the burner controls, follow this procedure.

1. Turn the thermostat temperature setting down and set the operating mode to "OFF" or "COOLING".
2. Remove the furnace front door.
3. Check to see if the light on the burner primary is on. If so, the control may have "locked out". To recycle the control system, depress the reset button. Refer to Figure 16.
4. Replace and secure the furnace front door.
5. Set the operating mode on the thermostat to "HEATING" and turn the thermostat temperature setting up.

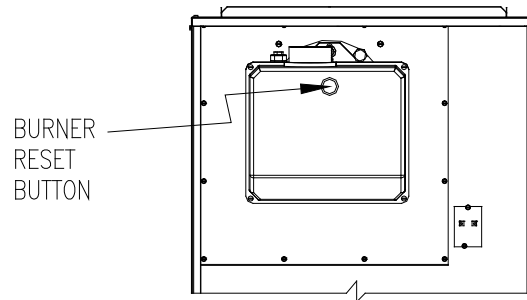

Fig-16

If this action does not reactivate the unit, contact a qualified service agency for assistance.

In general, if the thermostat is set in the heating mode, the heating system functions entirely automatically. However, under certain circumstances, the appliance may not be able to fire the burner. For instance, if the manual oil shutoff valve has been closed or the oil tank is out of fuel, the oil line may have air trapped in it. It will be necessary to purge the air by bleeding the supply line from the tank to the burner again for the heating system to operate. Refer to the instructions under the **Extended Appliance Shutdown** section of this manual.

NOTICE: Thermo Products recommends that the user/homeowner, contact a qualified service agency for assistance in bleeding the fuel line(s) and lighting off the heating section.

The following maintenance points should be reviewed periodically to assure the heating and cooling systems continue to function properly.

⚠WARNING: Shut off unit and disconnect the power source before disassembling the unit.

⚠WARNING: Never operate the appliance without clean air filters in place.

⚠CAUTION: This appliance requires air for combustion, ventilation, and cooling. Do not block or obstruct air openings in the unit and the air space around the perimeter of the unit.

1. At least every three months, under normal usage conditions, check and clean all air filters in the appliance and, if present, in the duct system. If excessively dirty air filters are not cleaned, or changed, poor system performance will result due to reduced airflow. Low airflow places unnecessary strain on the compressor, possibly causing the system to shutdown on the refrigerant high-pressure switch. Refer to Figure 14 for a sketch of the filter location.
2. Do not allow the fuel oil tank to run completely empty. During the summer, keep the tank full to reduce condensation of moisture on the inside surface of the tank. If the fuel tank runs completely dry, it may be necessary to bleed air from the fuel lines. **Contact a qualified heating contractor to bleed the lines and restart the burner.**
3. Check the supply and return air connections to the appliance to insure the seals between the duct and appliance and the appliance and home are intact. Check the ducts for any signs of collapse, holes, or excessive corrosion. Repair or replace components as required.

VII. TROUBLESHOOTING:

THIS SECTION IS ONLY TO BE PERFORMED BY TRAINED, QUALIFIED SERVICE PERSONNEL, AND NOT BY THE FURNACE OWNER.

NOTICE: Before troubleshooting, familiarize yourself with the Initial Startup, Checkout Procedure, and Troubleshooting Flowchart.

Refer to the appendices of this manual for an electrical schematic, a connection diagram, flowcharts to assist in troubleshooting, product specifications, and a replacement parts list follow for this appliance.

1. Check for 115VAC line supply voltage to the furnace. If there is no supply voltage, check fuses and service switch.

CAUTION: When testing electrical equipment, always follow standard electrical procedures.

2. Make sure thermostat is calling for burner operation.
3. Check oil supply and make sure all valves are open.

The troubleshooting chart beginning on the following page should help identify the type of malfunction or deviation from normal operation. To use this diagram, just follow the instructions in the boxes. If the answer is yes or the condition is true, go down to the next box. If the answer is no or the condition is false, go to the box on the right. Continue checking and answering questions and conditions in each box until a problem and/or repair is found. After any maintenance or repair, the trouble shooting sequence should be repeated until normal system operation is achieved.

VIII. Sequence of Operations Flow Chart:

Mode of Operation
Standby
(at any time the oil valve is not energized)

Control System Action
Continuous safe operation check. If flame simulation condition present, system shuts off oil valve, ignitor, and burner motor; activates light on reset button.

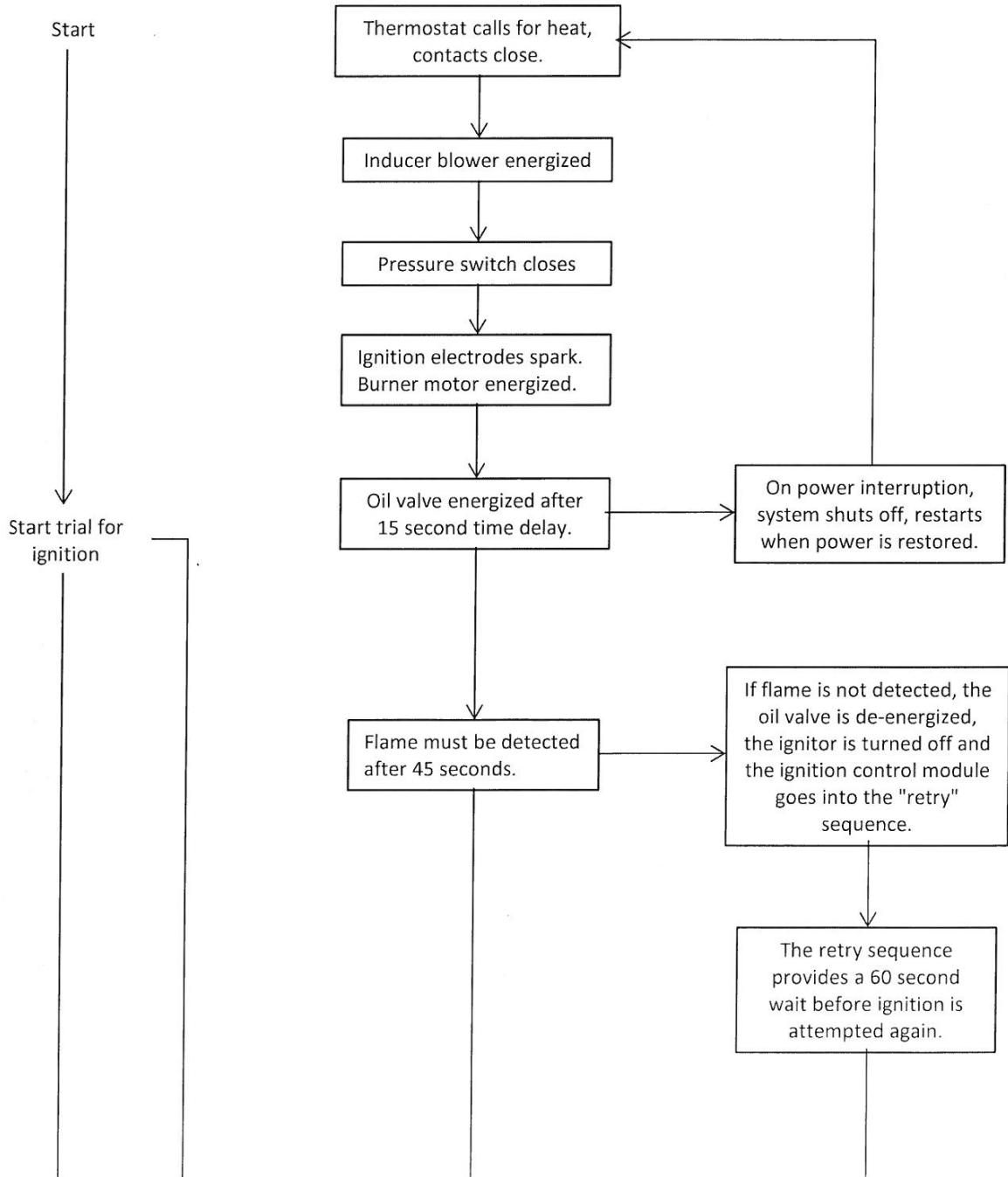

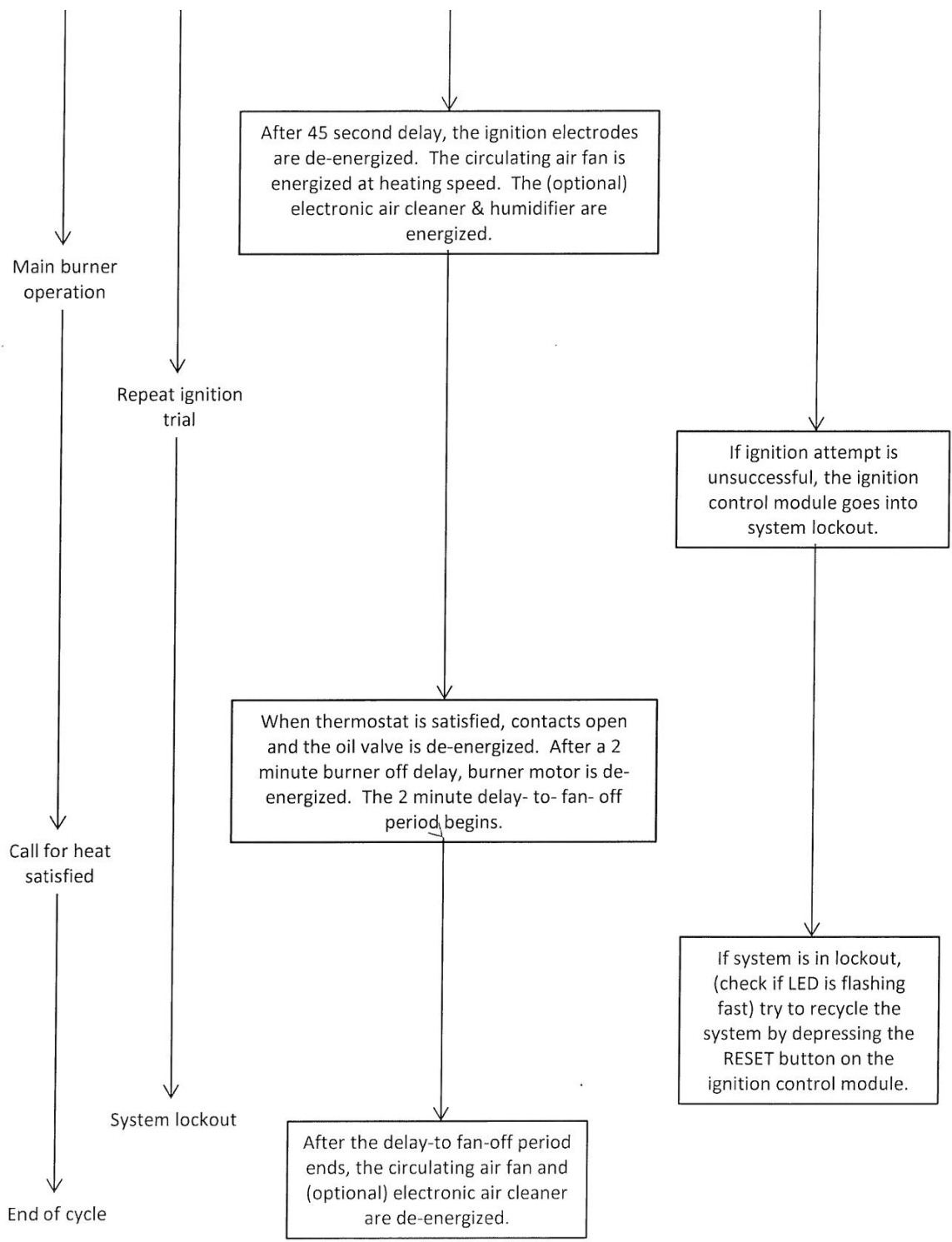

IX. Trouble Shooting Flow Chart

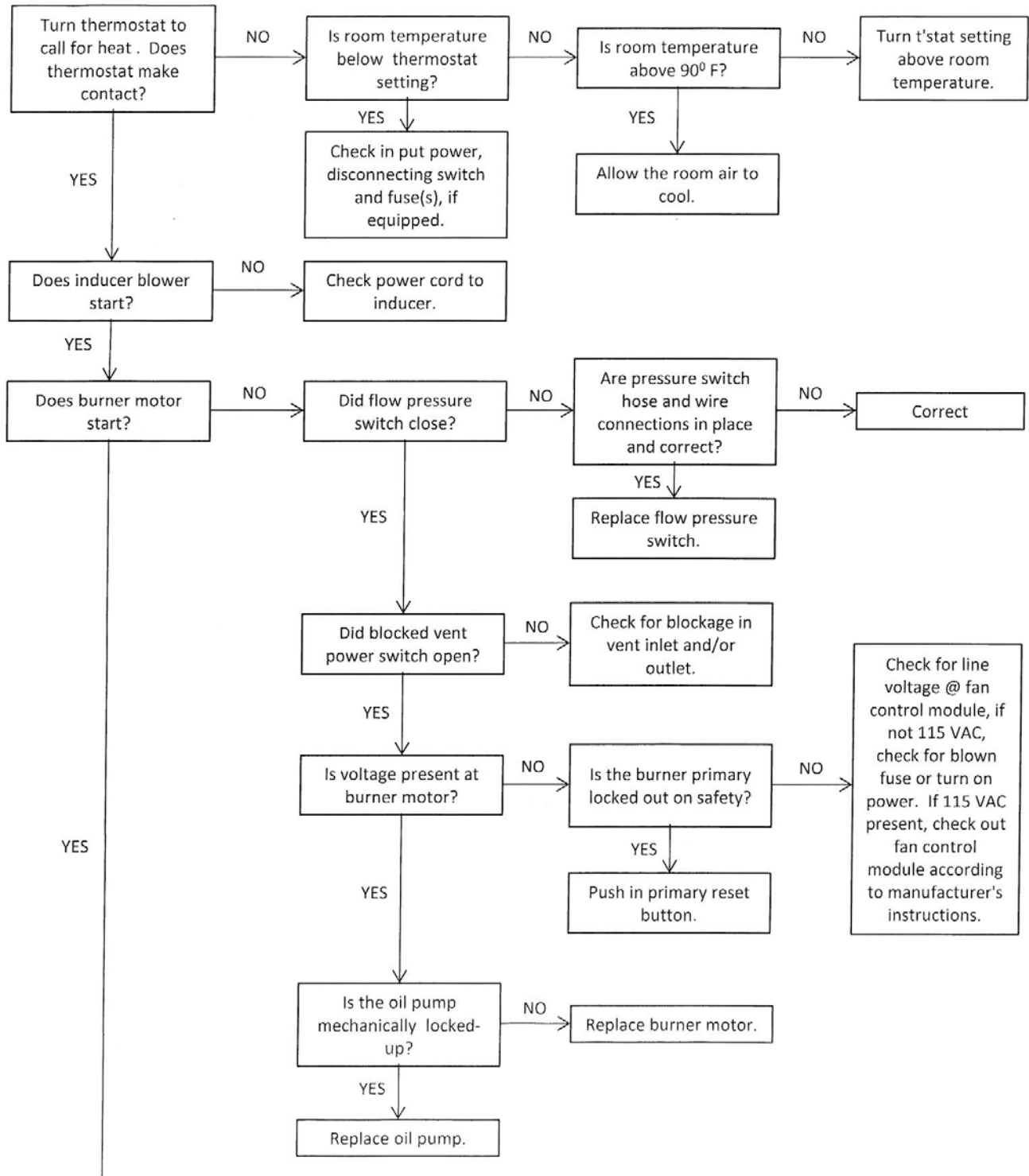

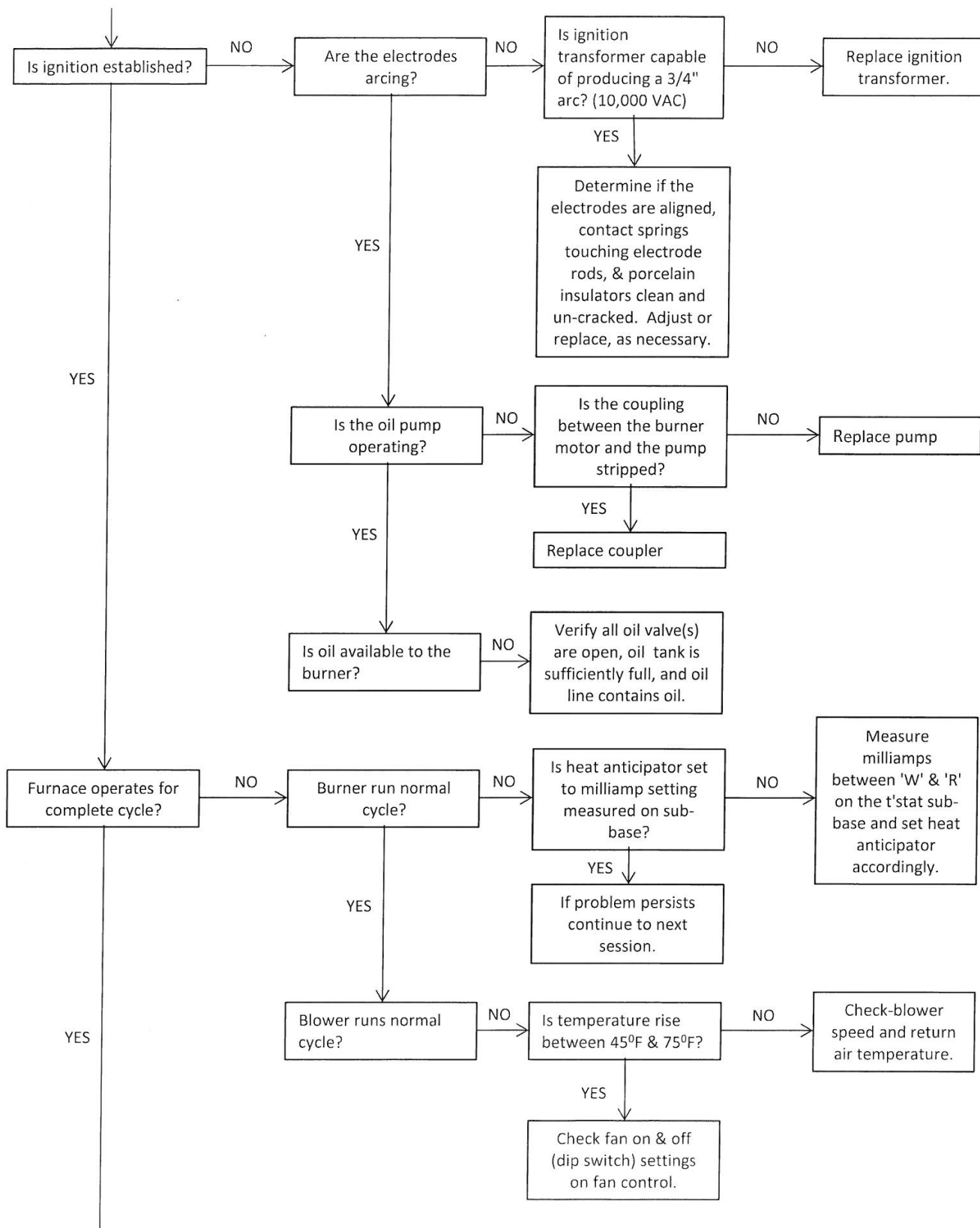

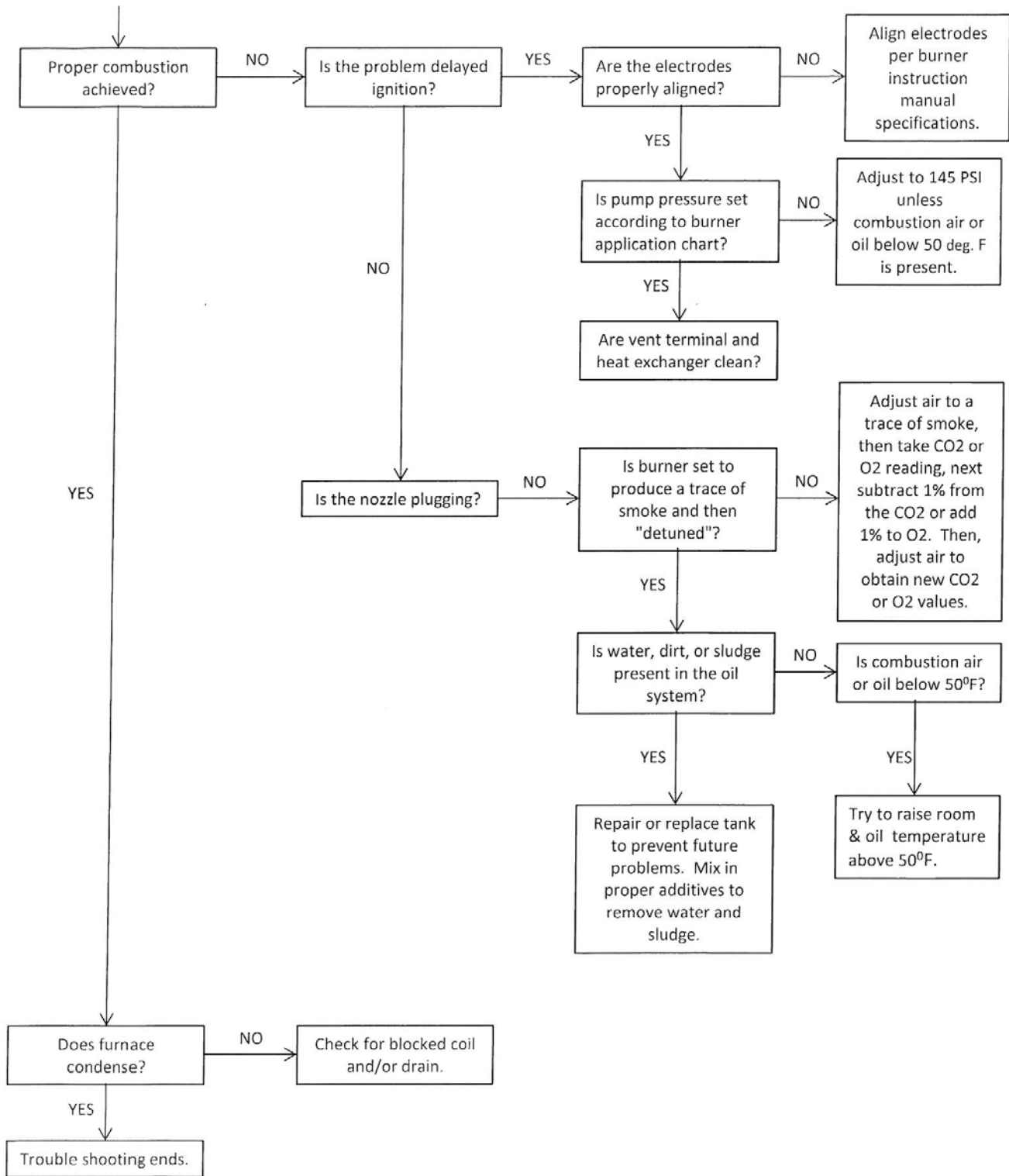

REPEAT PROCEDURE UNTIL TROUBLE FREE OPERATION IS OBTAINED.

**COMBUSTION AND EFFICIENCY TESTING FOR THERMO PRIDE
OIL FIRED CENTRAL FURNACES.**

Complete this form for each Thermo Pride furnace installed. Read instruction manual carefully before making tests. Retain this form with furnace.

CUSTOMER	NAME					
	ADDRESS					
	CITY, STATE					

HEATING SYSTEM	BURNER MODEL NO.	BLAST TUBE LENGTH	AIR SHUTTER OPENING % OF MAX. (EST)			
	COMBUSTION CHAMBER	CONDITION	MATERIAL	FURNACE MODEL		
	VENT SYSTEM DESCRIPTION					
	NUMBER OF 90° ELBOWS?		EXHAUST _____	INLET AIR _____		
	LENGTH OF STRAIGHT PIPE?		EXHAUST _____	INLET AIR _____		
	FUEL LINE FILTER		FURNACE SERIAL NUMBER			

COMBUSTION TESTS (OPERATE BURNER AT LEAST 10 MINUTES BEFORE STARTING TESTS.)			INITIAL INSTALLATION	SERVICE	SERVICE	SERVICE
	CO2 IN VENT PIPE					
	DRAFT OVERFIRE					
	DRAFT IN VENT PIPE					
	SMOKE NUMBER					
	GROSS STACK TEMP					
	FURNACE ROOM TEMP					
	NET STACK TEMP (GROSS STACK MINUS FURNACE ROOM TEMP)					
	EFFICIENCY					
	NOZZLE SIZE & SPRAY					
	OIL PUMP PRESSURE					
	OPERATION OF CONTROLS					
	BURNER SAFETY CONTROLS					
	CHECK OIL FOR LEAKS					
	TESTS TAKEN BY					
	DATE					
	NOTES					
	INSTALLER NAME & ADDRESS					

Appendix – A

Replacement Parts:

ITEM	SUB-ASSEMBLY PARTS DESCRIPTION	(CHCFAC720)VAR)	
		PART NO.	QTY.
1	BASE	14914	1
2	FRONT CENTER PANEL	14953	1
3	BLOCK -OFF, COIL	14954	2
4	BAFFLE, LEFT AIR SIDE	14955	1
5	BAFFLE, RIGHT AIR SIDE	14956	1
6	HEAT SHIELD RETAINER, COIL BOX	14960	1
7	BLOWER PAN	24915	1
8	OIL BURNER	380790	1
9	LIMIT SWITCH	350817	1
10	LIMIT SHIELD	14961	1
11	INSULATION BOOT	350036	1
12	DOOR PULL	320157	2
13	LATCH	320208	4
14	STRIKE	320209	4
15	CONDENSATE TRAP/FLOAT SWITCH	320821	1
16	HEAT EXCHANGER ASSEMBLY	34908	1
16A	LOWER HEAT SHIELD	380801	1
16B	REAR HEAT SHIELD	380802	1
17	BURNER MOUNTING PLATE	34911	1
17A	MOUNTING PLATE GASKET	330370	1
17B	MOUNTING PLATE HEAT SHIELD	380784	1
18	FILTER	370023	1
19	COMBUSTION CHAMBER	380785	1
20	CASING, BACK	614918	1
21	CASING, TOP REAR	614919	1
22	DOOR, BURNER ACCESS	614920	1
23	DOOR, BLOWER ACCESS	614921	1
24	ACCESS PANEL, HX	614925	1
25	FRONT SEPARATOR PANEL	614926	1
26	CASING, TOP FRONT	614962	1
27	FILTER RACK	624750-13	1
28	CASING, LEFT SIDE	624916	1
29	CASING, RIGHT SIDE	624917	1
30	PARTS PACKAGE	S00S4204	1
31	BLOWER ASSEMBLY	S00S4506	1
31A	BLOWER HSG W/ WHEEL	S00S4510	1
31B	MOTOR BRACKET ASSEMBLY	AOPS1670	1
31C	MOTOR	350208	1
31D	OIL FURNACE CONTROL	350822	1
31E	TRANSFORMER	350464	1
31F	RELAY DPST-NO	350828	1
31G	TIME DELAY REALY	350829	1
32	VESTIBULE HARNESS	350814	1
33	BLOWER COMPARTMENT HARNESS	350815	1

OHC BF3 RIELLO BURNER (380790)

ITEM	DESCRIPTION	TP PART #
1	AIR TUBE COMPLETE	380760
2	BLAST TUBE ONLY	380710
3	ELECTRODE ASSEMBLY	380712
4	PUMP	380633
5	MOTOR	380630
6	BLOWER WHEEL	380629
7	PRIMARY CONTROL	380449
8	PHOTO CELL	380628
9	INSULATING AMULET	380789
10	NOZZLE, .50 60°W	380387
11	COIL	380719
12	MTG FLANGE GASKET	330371

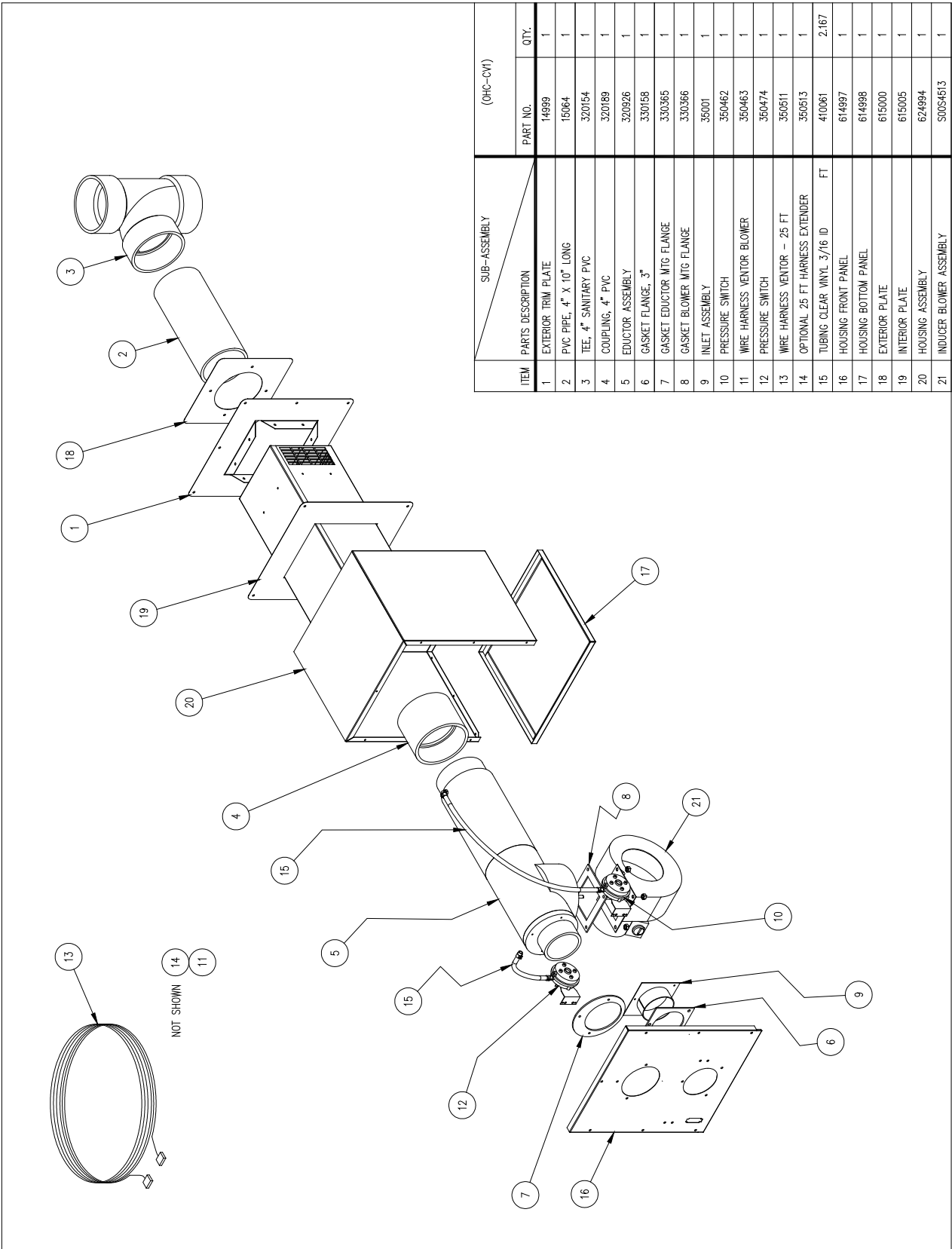

ITEM	PARTS DESCRIPTION	(OHC-CVI)	
		PART NO.	QTY.
1	EXTERIOR TRIM PLATE	14989	1
2	PVC PIPE, 4" X 10" LONG	15064	1
3	TEE, 4" SANITARY PVC	320154	1
4	COUPLING, 4" PVC	320189	1
5	EDUCTOR ASSEMBLY	320926	1
6	GASKET FLANGE, 3"	330158	1
7	GASKET EDUCTOR MTG FLANGE	330365	1
8	GASKET BLOWER MTG FLANGE	330366	1
9	INLET ASSEMBLY	36001	1
10	PRESSURE SWITCH	350462	1
11	WIRE HARNESS VENTOR BLOWER	350463	1
12	PRESSURE SWITCH	350474	1
13	WIRE HARNESS VENTOR — 25 FT	350511	1
14	OPTIONAL 25 FT HARNESS EXTENDER	350513	1
15	TUBING CLEAR VINYL 3/16 ID	410061	2.167
16	HOUSING FRONT PANEL	614997	1
17	HOUSING BOTTOM PANEL	614998	1
18	EXTERIOR PLATE	615000	1
19	INTERIOR PLATE	615005	1
20	HOUSING ASSEMBLY	624994	1
21	INDUCER BLOWER ASSEMBLY	S0054513	1

Appendix – B

Wiring Diagram

OHCFA072DV4R

